

Product information

mzr-2961 - Magnetic hermetic pump series



Description

The micro annular gear pump mzr-2961 is suitable for handling crystallizing, oxygen or moisture sensitive liquids, because the pump has no shaft seal. This functionality is made possible thanks to a liquid-separating cup surrounding the magnetic drive. The compact dimension of this magnetic hermetic pump is achieved by a completely new product design and optimal matching with an integrated speed controller. With a diameter of 22 mm and 69 mm in length, the pump weighs 115 g. The pump handles flow rates from 1.2 to 18 ml/min with a high precision and low pulsation. The pump is suitable for applications where an avoidance of leakage and a long service life as well as low energy consumption are important requirements. The pump is supplied with a terminal box for speed control and LED status indicator.

Advantages

- Hermetic pump design
pump without shaft seal
- Magnetic drive
inner magnet system driven by rotating magnetic field
- Integrated controller
supply voltage 24 V DC,
speed control by analog input 0-10 V
- Compact dimensions
diameter 22 mm, length 69 mm
- Long service life
wear-resistant, ultra-hard materials

Applications

- Fuel cells
- Dosing of AdBlue
- Biotechnology
- Marine technology
- Metering of liquefied gases
- Aerospace industry
- Mobile analytics

Technical data

Flow rate	1.2 - 18 ml/min
Displacement volume	3 µl
Maximum system pressure	6 bar (87 psi) (60 bar (870 psi)*) (inlet pressure + differential pressure)
Differential pressure range	0 - 3 bar (44 psi)
Liquid temperature range	-15 ... +60 °C (+5 ... +140 °F)
Viscosity range	0.3 - 100 mPas
Velocity range	400 - 6,000 rpm
Fluid connection	slip fittings with outside diameter 2 mm optional: manifold assembly M2.1
Wetted parts	stainless steel 316L, 318LN, ceramics, tungsten carbide Ni-based, epoxy resin; static seals: FPM, optional: EPDM, FFPM
Motor	canned BLDC-motor, 24 V DC, 8.9 W
Controller	integrated speed controller
Interface	0–10 V
Electrical connection	6-pole connector, Micro-Fit
Dimensions (L x W x H)	Ø 22 mm, length 69 mm
Weight	approx. 115 g (manifold assembly approx. 145 g)
Remarks	* Customized solution on request.

Notice

Even if single parameters are within the indicated performance range of technical data, certain parameter combinations may not be achievable. Single parameters may exceed their indicated performance range under adequate circumstances. For detailed evaluation please contact HNP Mikrosysteme. Actual performance may vary. Specifications are subject to change without notice.

Accessories

- Terminal box S-G61

Dimensions

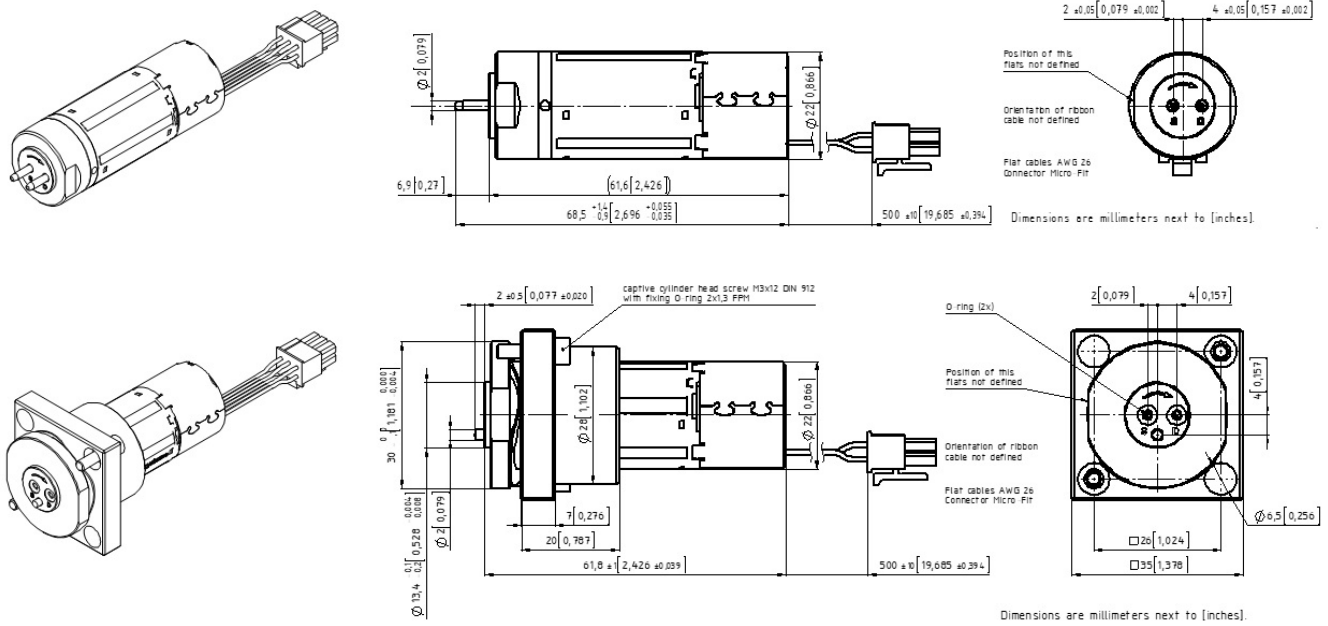

Flow charts

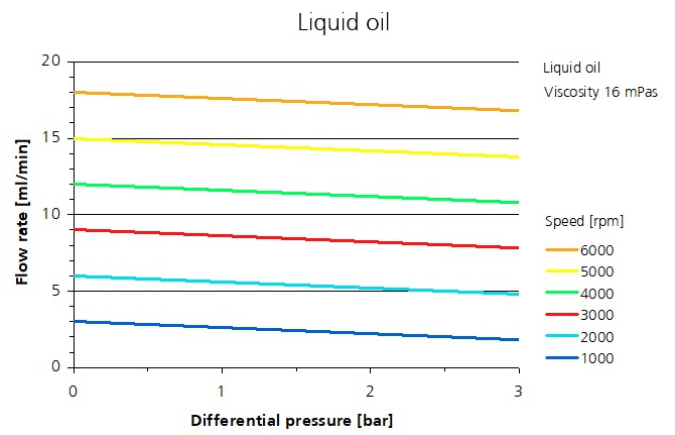
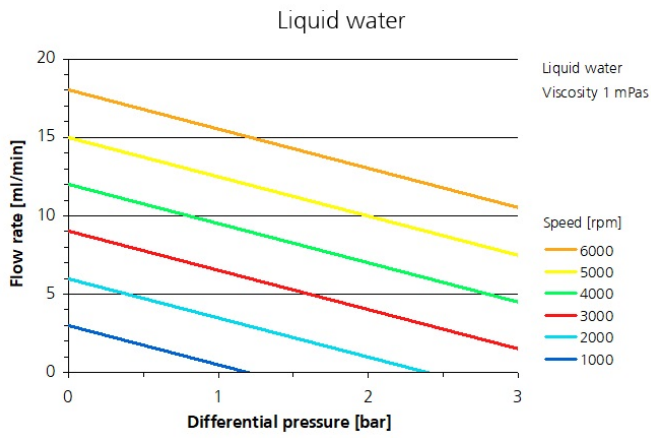

Patents and trademarks

Micro annular gear pumps (and housings) are protected by assigned patents: EP 1 354 135 B1; US 7,698,818 B2; DE 10 2011 001 041 B4; CN 103 348 141 B; US 10,012,220 B2; CN 103 732 921 B; US 9,404,492 B2; US 6,520,757 B1.
HNP M[®], mzr[®], MoDoS[®], μ -Clamp[®], μ Dispense[®], Centifluidic Technologies[®], LiquiDoS[®], smartDoS[®], ColorDoS[®] are registered German trademarks of HNP Mikrosysteme GmbH.

Contact

HNP Mikrosysteme GmbH
Bleicherufer 25
19053 Schwerin
Germany

T +49 385 52190-300
F +49 385 52190-333
info@hnp-mikrosysteme.de

Last update 2019/10