

Product information

Filter-pump-valve functional module F-P-V · Functional modules



Description

The filter-pump-valve functional module F-P-V allows the combination of micro annular gear pump, filter and valve with short direct connections for precise and reproducible dosing. The void volume of this compact system is low and the expenses of connecting elements are obsolete. The integrated wire mesh filter with a mesh size of 10 µm preventatively protects the pump as well as the downstream fluidic micro structures from contamination with particles. Replacement of the easily accessible filter is uncomplicated, removing the pump is unnecessary. The functional module can be used flexibly for several sizes of pumps of the low pressure and magnetic hermetic pump series. Compared to the basic module F-P the module format F-P-V features a small, chemically resistant 2/2- or 3/2-way shift valve, used for the almost backstroke free blockage of the fluid line to prevent the backflow of fluid through the pump. This functional module is especially well-suited for highly precise discrete dosing in aspirate and dispense mode.

Advantages

- Low void volume integration of micro annular gear pump, filter and valve
- Compact dimensions, low weight 40 x 58.8 x 46 mm, approx. 271 g (resp. without pump)
- Flexible use for mZR-pumps low pressure series: mZR-2521, mZR-2921, mZR-4622; magnetic hermetic series: mZR-296x, mZR-466x; all pumps with manifold assembly M2.1
- Wide range of volume flows 0.15 - 9 ml/min; 0.3 - 18 ml/min and 1.2 - 72 ml/min
- Safe operation with wire mesh filter Protection of pump and downstream fluidic structures from particles
- Chemical resistant miniature valve 2/2- or 3/2-way-magnetic valve for precise and reproducible dosage and blockage of backflow of fluids
- Easy replacement of pump and filter mounting of functional module via stainless steel sheet

Applications

- Analytical instrumentation
- Laboratory automation
- Diagnostics
- Biotechnology
- Micro reaction technology
- Research and Development

Technical data

Flow rate	pump specific 0.15 - 72 * ml/min
Differential pressure range	pump specific 0 – 1.5 bar, 0 - 2 bar 0 – 3 bar *
Maximum inlet pressure	1 bar
Liquid temperature range	0 ... +50 °C
Viscosity range	0.3 - 10 mPas
Internal volume	450 µl (without pump)
Fluid connection	1/4"-28 UNF
Mounting parts	2x M2.5x7
Filter	mesh wire filter, mesh size 10 µm, filter area 1.3 cm ²
Valve	2/2 shift valve NC, pressure range 0 – 3 bar, operating voltage 24 V DC, assigned power rating 1 W; optional: 3/2-way-valve
Wetted parts	filter: stainless steel 316L, epoxy resin; static seals: FPM, optional: FFPM, EPDM; manifold adapter: stainless steel 316L; valve: PEEK™, FFPM
Dimensions (L x W x H)	40 x 58.8 x 46 mm (without pump)
Weight	approx. 271 g (without pump)
Remarks	* depending on pump

Notice

Even if single parameters are within the indicated performance range of technical data, certain parameter combinations may not be achievable. Single parameters may exceed their indicated performance range under adequate circumstances. For detailed evaluation please contact HNP Mikrosysteme. Actual performance may vary. Specifications are subject to change without notice. This document is subject to change without notice.

Dimensions

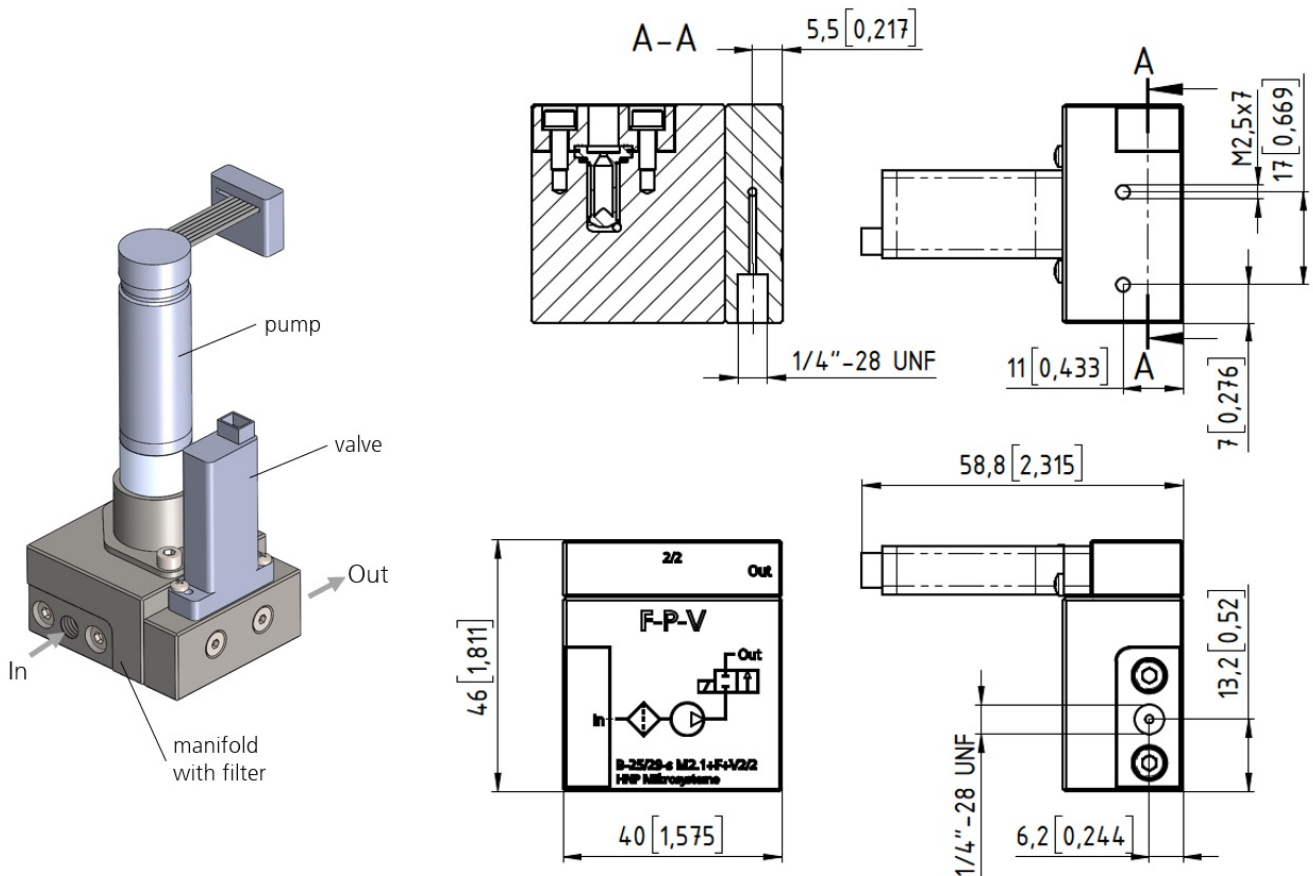

Patents and trademarks

Micro annular gear pumps (and housings) are protected by assigned patents: EP 1 354 135 B1; US 7,698,818 B2; DE 10 2011 001 041 B4; CN 103 348 141 B; US 10,012,220 B2; CN 103 732 921 B; US 9,404,492 B2; US 6,520,757 B1.

HNP[®], mzi[®], MoDoS[®], μ -Clamp[®], μ Dispense[®], Centifluidic Technologies[®], LiquiDoS[®], smartDoS[®], colorDoS[®] are registered German trademarks of HNP Mikrosysteme GmbH.

Contact

HNP Mikrosysteme GmbH
 Bleicherufer 25
 19053 Schwerin
 Germany

T +49 385 52190-300
 F +49 385 52190-333
 sales@hnp-mikrosysteme.de

Last update 2023/06