

Operation manual for micro annular gear pumps  
**mzr-11545X1**



HNP Mikrosysteme GmbH  
Bleicherufer 25  
D-19053 Schwerin (Germany)  
Telephone: +49 385/52190-301  
Telefax: +49 385/52190-333  
E-mail: [info@hnp-mikrosysteme.de](mailto:info@hnp-mikrosysteme.de)  
<http://www.hnp-mikrosysteme.de>

Last update: October 2019

## **Impressum**

Original instructions

Copyright  
HNP Mikrosysteme GmbH  
Bleicherufer 25  
D-19053 Schwerin

All rights, including translation, reserved.

Without prior explicit written permission of HNP Mikrosysteme GmbH no part of this manual may be, copied, reproduced or processed.

This manual has been prepared with care. HNP Mikrosysteme does assume no liability for any errors in this manual and resulting consequences. Likewise, no liability is assumed direct or subsequent damages arising from an incorrect use of the devices.

While using micro annular gear pumps, the relevant standards regarding the specifications of this manual have to be followed.

Subject to change without notice.

# Contents

<b>1</b>	<b>General Information</b>	<b>3</b>
1.1	Application scope of the pumps	3
1.2	Pump Model Designation	4
1.3	Technical data of the micro annular gear pumps mzr-11545X1	5
1.4	Measurements	6
1.5	Flow charts	7
1.6	Technical data of the motor of mzr-11545X1	8
<b>2</b>	<b>Safety</b>	<b>9</b>
2.1	Labelling of instructions in the operating manual	9
2.2	Staff qualification and training	9
2.3	Dangers from non-compliance with safety instructions	9
2.4	Safety-conscious work	9
2.5	Safety instructions for the operator	10
2.6	Safety instructions for maintenance, inspection and assembly work	10
2.7	Unauthorised conversions and spare parts manufacturer	10
2.8	Improper modes of Operation	10
2.9	General safety instructions	10
<b>3</b>	<b>Transportation and Storage</b>	<b>12</b>
3.1	Shipping	12
3.2	Transportation	12
3.3	Interim storage	12
<b>4</b>	<b>Description of the micro annular gear pump</b>	<b>13</b>
4.1	Operating principle of the micro annular gear pump	13
4.2	Construction	15
4.3	Construction materials	15
4.4	Fluidic connectors	16
<b>5</b>	<b>Optional modules</b>	<b>17</b>
5.1	Fluidic seal module	18
5.2	Heat insulation module	21
<b>6</b>	<b>System integration</b>	<b>22</b>
6.1	Check before installation	22
6.2	Mounting of the micro annular gear pump	22
6.3	General instructions for the assembly of the liquid supply network	22
6.4	Assembly instruction for tubing and accessories	23
6.5	Filter selection and use	25

<b>7</b>	<b>Motion Controller</b>	<b>26</b>
<b>8</b>	<b>Start Up / Shut Down</b>	<b>27</b>
8.1	Preparing for operation	27
8.2	Startup of the micro annular gear pump	27
8.3	Flushing procedure after use	27
8.4	Shutdown of the micro annular gear pump	30
8.4.1	Conservation	32
8.4.2	Dismantling of the system	33
8.5	Trouble shooting	34
8.6	Return of the micro annular gear pump to the manufacturer	34
<b>9</b>	<b>Software » K4ConfigTool «</b>	<b>35</b>
<b>10</b>	<b>Problems and their removal</b>	<b>36</b>
<b>11</b>	<b>Accessories for microfluidic systems</b>	<b>38</b>
<b>12</b>	<b>Non-liability clause</b>	<b>38</b>
<b>13</b>	<b>Service and maintenance</b>	<b>38</b>
<b>14</b>	<b>EC Directive</b>	<b>39</b>
14.1	Electromagnetic Compatibility (EMC)	40
14.1.1	EMC Directive and Standards for controller S-BL	40
14.1.2	Information on use as intended	41
<b>15</b>	<b>Declarations of conformity</b>	<b>42</b>
<b>16</b>	<b>Service, maintenance and warranty.</b>	<b>47</b>
<b>17</b>	<b>Contact persons</b>	<b>48</b>
<b>18</b>	<b>Legal information</b>	<b>49</b>
<b>19</b>	<b>Safety information for the return of already employed micro annular gear pumps and components</b>	<b>50</b>
19.1	General information	50
19.2	Declaration of liquids in contact with the micro annular gear pump	50
19.3	Shipment	50
<b>20</b>	<b>Declaration of media in contact with the micro annular gear pump and its components</b>	<b>51</b>
<b>21</b>	<b>Supplement</b>	<b>52</b>

# 1 General Information

This operating manual contains basic instructions to be followed during integration, operation and maintenance of a mzr® micro annular gear pump. For this reason it is necessary to read it carefully before any handling of the device. The present manual should always be kept at the operation site of the micro annular gear pump.

In case assistance is needed, please indicate the pump type visible on the housing.

## 1.1 Application scope of the pumps

The micro annular gear pumps described in this manual are suitable for continuous delivery and discrete dosage of water, watery solutions, solvents, methanol, oils, lubricating liquids, paints and varnishes as well as many other liquids.



If you intend to treat any aggressive, poisonous, or radioactive liquids, you must conform to safety measures as according to the regulations in force. Any project concerning handling of corrosive liquids should be previously discussed with the pump manufacturer.



The micro annular gear pumps *must not* be used for invasive medical applications, in which the liquid having had contact with the pump is re-introduced to the body.



Micro annular gear pumps exclusively are provided for use in the industrial area. A private use is excluded.



The micro annular gear pumps *must not* be used in aircrafts and spacecrafts or other vehicles without prior consent of the manufacturer.



Data concerning resistance of the pumps to the manipulated liquids have been elaborated according to the best of HNPM's knowledge. However, operating parameters varying from one application case to another, no warranty for this information can be given.



Information given in this manual does not release the customer from the personal obligation to check the integrity, correct choice and suitability of the pump for the intended use. The use of the micro annular gear pumps should be conform with technical norms and regulations in force.

If you wish to receive more information than comprised in this operating manual please contact directly HNP Mikrosysteme.

## 1.2 Pump Model Designation

This manual is valid for the micro annular gear pump mzr-11548 and mzr-11548X1, manufactured by HNP Mikrosysteme GmbH, Bleicherufer 25, D-19053 Schwerin, Germany.

The bottom line of this manual shows the issue and date of issue of this operating instruction.

### 1.3 Technical data of the micro annular gear pumps mZR-11545X1

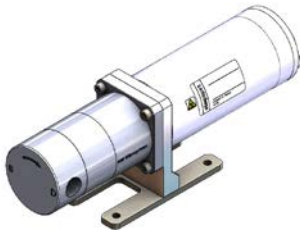
<b>mZR-11545X1</b>	
Design	
	
<b>Constructive Specifications</b>	
Displacement volume	192 µl
Measurements (L x W x H)	261 x 63 x 93,3 mm
Weight	approx. 3.7 kg
Internal volume	8,5 ml
Material case	stainless steel 1.4404, 1.4435 (316L)
Material rotor	tungsten carbide Ni-based
Material bearing	tungsten carbide Ni-based
Shaft seal	graphite-reinforced PTFE, spring Alloy C276 (2.4819)
Static seals	FPM (fluoroelastomer), optional: EPDM, FFKM
Fluid connections	3/8" NPT internal thread, lateral
<b>Technical data</b>	
Flow rate	0,192 – 768 ml/min (= 46,08 l/h)
Smallest dosage volume	100 µl
Operating pressure range	0 – 10 bar (by Viskosity 1 mPas)
Max. inlet pressure	5 bar
Viscosity range	0,3 – 10.000 mPas
Precision	< 1 %
Pulsation	6 % (theoretical)
Operating temperature	0 ... +40 °C
Ambient temperature	0 ... +40 °C
Store temperature	5 ... +30 °C

caption: \* Differing specifications on request

table 1

Technical data of the micro annular gear pump head mZR-11545X1

**Warning**

The material properties of a liquid (e.g. viscosity, lubricating property, particle content, corrosiveness) impacts the technical data and the lifetime of pumps. Under appropriate conditions the characteristic values may be increased or decreased.

**Warning**

If you intend to operate the pump out of the range of the above given specification, please consult the manufacturer. Modifications may be necessary to ensure successful operation. Otherwise the pump or the system may be damaged seriously.

### 1.4 Measurements

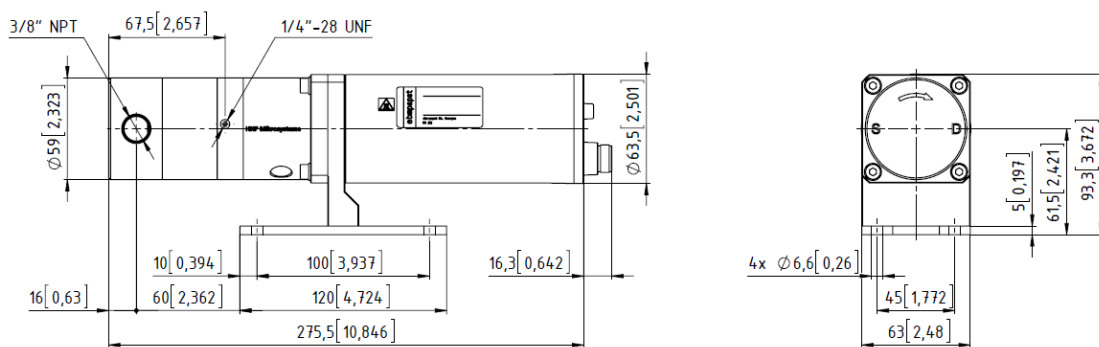

figure 1 Dimensions of the micro annular gear pump mzr-11545X1



### 1.5 Flow charts

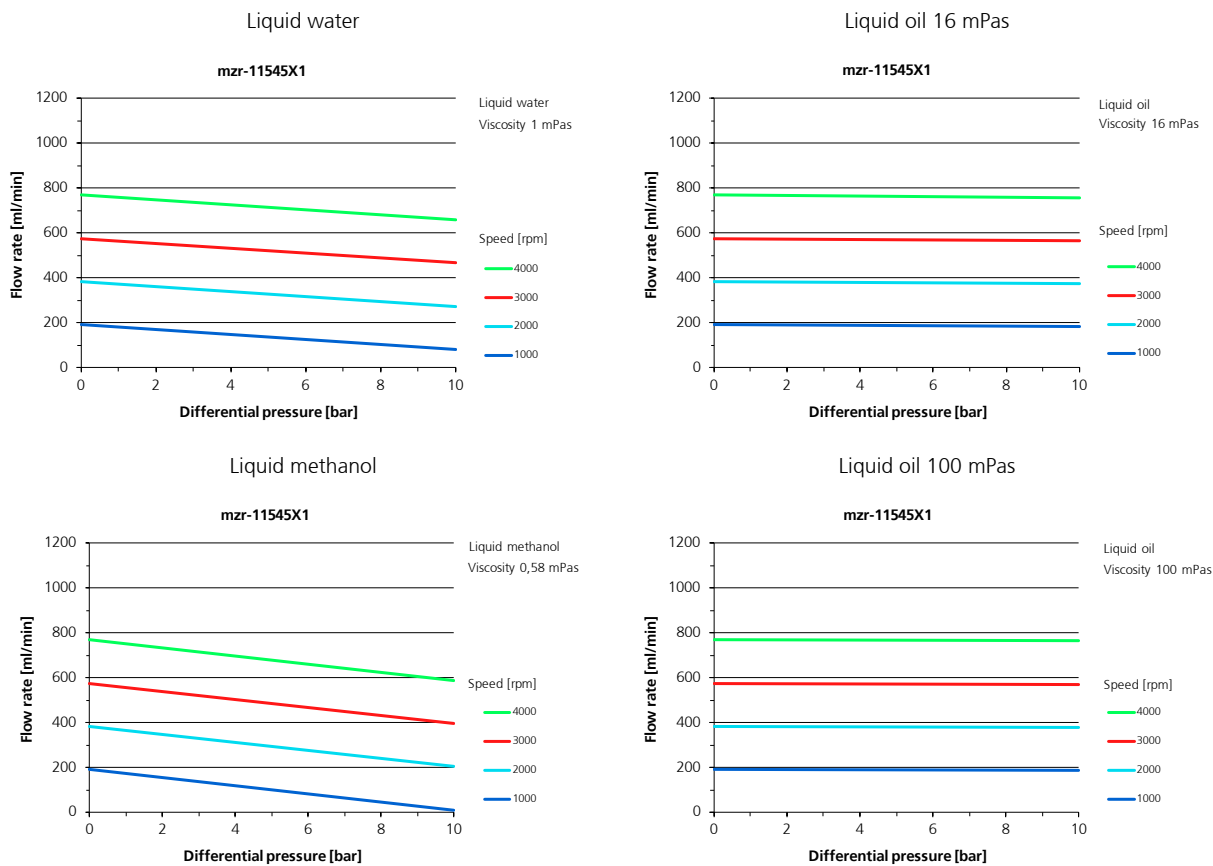

figure 2 Flow charts of the micro annular gear pump mZR-11545X1

## 1.6 Technical data of the motor of mzr-11545X1

The micro annular gear pump mzr-11545X1 can alternatively be driven with a brushless DC-motor. It is characterized by higher dimensions and a wider speed range, which covers entirely the speed range of the micro annular gear pump and shows a longer service life than a brushed DC-motor.

Performance parameters	
Nominal voltage	48 V (40 ... 53 VDC)
Max. continuous torque	750 mNm
Power	251 W
Continuous current	7,2 A
Speed	50 – 4000 rpm
Ambient temperature	0 ... +40 °C

table 2

Technical data of the brushless DC-motor



For the motor connections, please read the separate operating instructions of the manufacturer. The motor is preset in the parameters.

## 2 Safety

Comply with the general safety instructions listed in this safety section and also with the special safety instructions listed under the other main sections.

### 2.1 Labelling of instructions in the operating manual

The safety instructions are listed in this operating manual which, if not complied with, can cause danger, are specially labelled by

Danger symbol		Non-compliance poses danger for persons.
High voltage symbol		Non-compliance poses danger of electrical shock.
Warning symbol		Non-compliance poses a risk to the machines

The name plate mounted on the pump must be complied with and be maintained in a clearly readable condition.

### 2.2 Staff qualification and training

The operational, maintenance, inspection and assembly staff must evidence the appropriate qualifications for these works. Areas of responsibility, competencies and monitoring of the staff must be precisely regulated by the operator. If the personnel do not have the necessary knowledge, they must be trained and instructed accordingly. This can be implemented, if necessary, by the manufacturer / supplier on behalf of the machine operator. In addition, the operator must ensure that the content of this operating manual is fully understood by the personnel.

### 2.3 Dangers from non-compliance with safety instructions

Non-compliance with safety instructions can pose a danger not just to personnel, but also to the environment and machinery. Non-compliance with the safety instructions can lead to the loss of all claims for compensation.

In detail, non-compliance can cause the following dangers (examples):

- Failure of important machine/system functions
- Failure of prescribed methods for maintenance and servicing
- Danger to persons from electrical, mechanical and chemical effects
- Danger to the environment from escaping hazardous substances

### 2.4 Safety-conscious work

The safety instructions listed in this operating manual, the applicable national regulations for accident prevents and all internal working, operating and safety regulations of the operator must be complied with.

## 2.5 Safety instructions for the operator

- If hot or cold machine parts pose any danger, these parts must be protected on site against contact.
- Leaks (e.g. from the shaft seal) of dangerous conveyed goods (e.g. explosive, toxic, hot) must be guided away in such a manner that no danger is present for persons and the environment. Legal requirements must be complied with.
- Danger posed by electrical energy must be excluded

## 2.6 Safety instructions for maintenance, inspection and assembly work

The operator must ensure that all maintenance, inspection and assembly work is carried out by authorised and qualified specialist personnel, who are sufficiently familiar with this operating manual.



In general, work on the machine should only be implemented when it is at a standstill. The procedure described in this operating manual to stop the machine must be complied with in full.



Pumps or aggregates that convey media hazardous to health must be decontaminated. Immediately after work is complete, all safety and protection equipment must be remounted/restarted.



Before commissioning, the points listed in the Initial start-up section must be noted.

## 2.7 Unauthorised conversions and spare parts manufacturer

Conversions or modifications to the machine are only permitted following consultation with the manufacturer. Original spare parts and accessories authorised by the manufacturer ensure safety. The use of other parts may annul the liability for any resulting consequences.

## 2.8 Improper modes of Operation

The operating safety of the delivered machine is only ensured by its correct use as per chapter 1 in this operating manual. The limit values given in the manual must not be exceeded in any case.

## 2.9 General safety instructions



Skilled personnel may only do *mounting* and *initial operating* of micro annular gear pumps.



The pump can achieve *high pressures*. Use only the fluidic connections included in the delivery and be sure, that *fittings* and *tubes* are *permissible* and *specified* for these pressures.



In order to decrease the pressure, provide the system with a *pressure control valve* directing the excess liquid to the storage tank or back to the suction side. In the case of blockage of the pressure side the operating pressure can multiply, this can lead to the damage of downstream components.



The micro annular gear pump is highly precise manufactured. Any kind of contamination on the inside of the pump can cause damages. Therefore, we may ask you, to ensure yourself, that all fluidic leading parts are absolutely free from any kind of dirt, dust or any other particles, as these impurities may affect the function of the pump.



For operating of the micro annular gear pump, the use of filters with a pore size of 10 µm or smaller is required.

Warning

To connect the tubes of the pump remove the transport plugs and adapt them to the fittings, which are found in the delivery volume (see: assembly instructions for fluidic connections).



Pay attention to the *correct assembly* of your *fluidic connections* on the micro annular gear pump head, to keep up the indicated *flow direction*. Should you intend to use the pump in reverse operation modus, we may ask you to contact one of our Applications Consultants at HNP Mikrosysteme, as this kind of operation is not possible in every range of application.



If you intend to use *aggressive, corrosive or poisonous, etc. pumping media*, you are obligated to take care of the appropriate safety precautions in accordance of law and regulations.



Information about *media constancy* is given by best knowledge of HNP Mikrosysteme. According to the variations of parameter referring to the variety applications, we are *not able* to take a *warranty* upon these specifications.



The *rotary shaft seals* used in the micro annular gear pump avoid in standard operation the leaking of media from the micro annular gear pump. Micro annular gear pumps are »technically sealed«, but *not hermetic sealed*, so that gases may escape from the pump or lead into the pump.



Take measures of precaution to avoid damages on close by equipment and avoid pollution of the environment, in case of disengagement. Be careful to assemble the micro annular gear pump, so that disengaging fluidic media may not leak into the motor or the control unit in case of malfunction.



In standstill, the medium in the pump may float in direction of the drop of pressure through the pump. If necessary provide *back pressure valves* (see: accessories).

Warning

*Avoid in any case dry running* of your *micro annular gear pump* as this may especially damage the seals. A short phase of dry running when setting the pump into operation is negligible.

Warning

Do not disassemble the micro annular gear pump in case of malfunction; contact our service personnel of HNP Mikrosysteme immediately to be helped.



Protect the micro annular gear pump and the electric actuator from *shock and at zero impact*.



The actuators may be protected against *moisture, dust and perspiration*.



The *permitted electrical data* of the actuators may *not be exceeded*. Notice that especially *the accurate set polarity* of the distribution voltage is required, if not the control unit can be destroyed.

**Warning**

The *surface temperature* of the *actuators* can exceed 60°C (140°F) in *full load*. You might want to *provide protection* to *avoid accidental contact*, which will cause burns on your skin.

## 3 Transportation and Storage

### 3.1 Shipping

The pumps are shipped from the factory in such a manner that they are protected against corrosion and against shocks.

In addition, inlets and outlets are plugged with protective plugs. This measure is necessary to securely prevent foreign bodies from penetrating into the pump's interior.

### 3.2 Transportation

To avoid transport damage, the transport packaging must be protected against shocks.

HNP Mikrosysteme guarantees that the shipped goods are in perfect condition at the time of delivery. The pumps must be immediately checked for transport damage once the pumps have been received. If damage is noted, the shipper responsible and the pump manufacturer must be informed immediately.

### 3.3 Interim storage

The following points must be obeyed for storing the pumps:

- Do not store the pumps in wet or damp rooms
- Protective plugs must be left screwed in
- Store temperature see according section 1.3 of this manual

## 4 Description of the micro annular gear pump

### 4.1 Operating principle of the micro annular gear pump

Micro annular gear pumps are positive displacement pumps. They contain two rotors, bearing slightly eccentrically to each other; an externally toothed internal rotor and an annular, internally toothed external rotor (see figure 3). Due to their cycloid indenting, the rotors remain interlocked at any time, forming during rotation a system of several sealed pumping chambers. As the rotors revolve around their offset axis, the pumping chambers increase on the induction (suction) side and simultaneously decrease on the delivery side of the pump (see figure 4). A homogenous flow is generated between the kidney-like inlet and outlet.

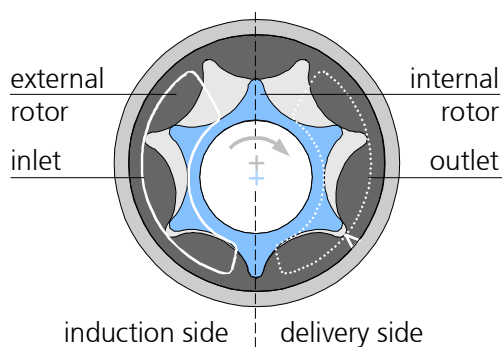

figure 3

Principle of the micro annular gear pump

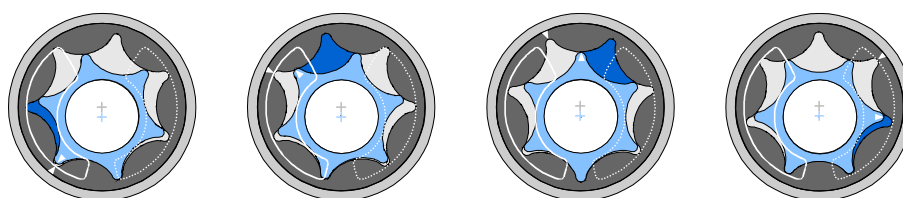

figure 4

Operating principle of the micro annular gear pump

Reciprocating and rotary pumps have a direct allocation to the fed amount of the displacement volume  $V_g$  of the pump and its actuator's number of revolutions  $n$ . The displacement volume describes the volume, which is theoretically fed with each revolution. The coherence of the flow rate referring to the formula (= volumetric flow rate)  $Q$  of the pump is:

$$Q = \eta_{Vol} \cdot V_g \cdot n$$

The volumetric efficiency  $\eta_{Vol}$  shows the relationship between the actual and the theoretical flow rate. The existing differences result from internal movement of the liquid during the operation.

*Example:* The pump head mzr-11540 has a displacement volume of 192  $\mu\text{l}$ . On the assumption that the volumetric efficiency is 100%, the flow rate at a speed of 3000 RPM would be 576 ml/min, according to the above formula. The table 4 shows theoretical flow rate values depending on speed expressed in ml/min and l/h.

RPM	Q [ml/min]	Q [l/h]
100	19,2	1,15
500	96	5,76
1000	192	11,52
2000	384	23,04
3000	576	34,02
4000	768	46,08

table 3

Theoretical flow rate of the micro annular gear pump mzr-11545X1

The pressure, which the pump has to generate, is given by the construction of the fluidic system and the results of the hydrostatic pressure and the hydraulic resistants (given by tubes, contractions etc.).

The viscosity of the pumping medium has an important influence on the volumetric efficiency. The volumetric efficiency increases with higher viscosity according to the smaller disengagement through the gaps of the pump.

Cavitation is an effect, which can result in a specific ceiling speed. The reason for this is the static pressure reaching the steam pressure of the liquid in the inlet port of the pump. In this state an increase of speed does not result in an increased flow rate. The formation of gas prevents a sufficient feeding of the pump. With increasing viscosity of the liquid (e.g. > 10.000 mPas), the ceiling speed is lower.

The specific feature of the mzr-pumps is their highly precise design, as well as the guarantee of high accumulator pressure and high accuracy in flow rate and dosage. Therefore, space width and transverse space width of the rotors as well as the interspace to the adjacent case parts are in the range of just a few micrometers. This precision is the condition to achieve a volumetric efficiency in the range of approx. 100 %.



## 4.2 Construction

The micro annular gear pump consist of the pump head, coupling assembly, motor and bracket (see figure 5).

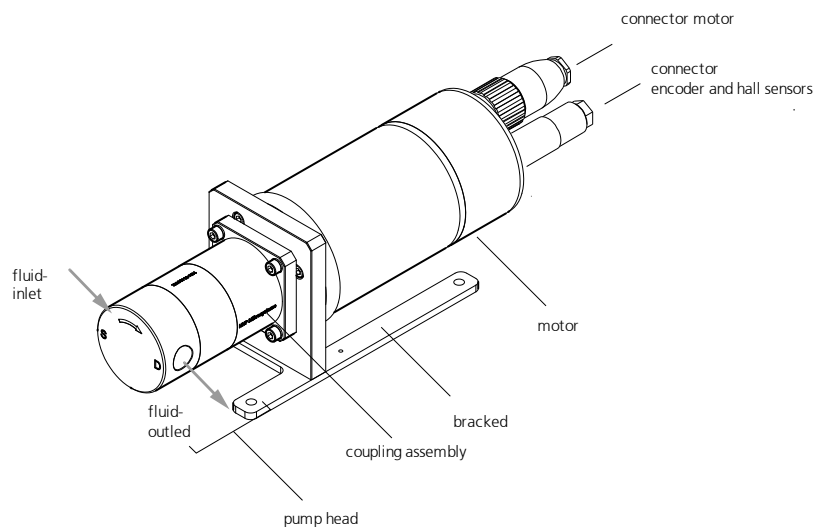

figure 5 Design of the micro annular gear pump (example with mzr-11548)

## 4.3 Construction materials

Components	
Case	stainless steel 1.4435 (316L)
Rotor, shaft, bearing	tungsten carbide Ni-based
Shaft seal	graphite-reinforced PTFE, spring Alloy C276 (2.4819)
Static seals	FPM (fluoroelastomer), optional: EPDM, FFPM

table 4 Materials of the components

The resistance of the construction materials to the delivered liquids should be verified by the operator for each individual application. Pumps handling non-lubricating liquids have shorter service lives.

#### 4.4 Fluidic connectors

The micro annular gear pump head has an inscription on the front side (see figure 6). The liquid inlet connection is marked with the letter »S«, the liquid outlet connection with the letter »D«. An arrow indicates the inherent turning direction of the shaft.

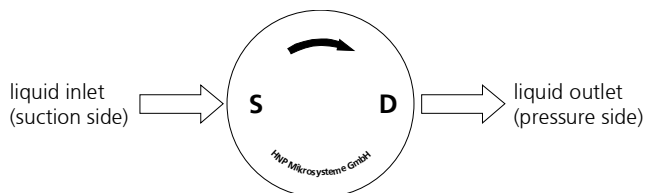

figure 6

Indication of the turning direction and fluidic connections on the front of the micro annular gear pump

The pump head has two inner threads for the connection of tube fittings. The pump head is available either in a version for lateral connections with 3/8" NPT fittings.

Sealing plugs are inserted into the holes for the fluidic connections as protection against contamination during delivery. The sealing plugs have to be removed before assembly of the fluidic connectors. If the fluidic connectors are disassembled, please re-seal the threads with the cleaned sealing plugs as protection against particles.

## 5 Optional modules

The spectrum of applications of the high performance micro annular gear pump series may be expanded by using different additional modules. The modules allow for special applications, which could otherwise not be accomplished with a standard pump version. The modules may be combined with each other and with almost all available pump heads and motor versions.

- *Fluidic seal module* prevents possible chemical reactions between the delivered liquid and the surrounding environment
- *Thermal insulation module* extends the operating temperature range of the pump by protecting the motor from overheating

The configuration of a given pump version should in each case be discussed with consideration to the specific requirements of the application. *Additional* customized modules may be designed on demand.

## 5.1 Fluidic seal module

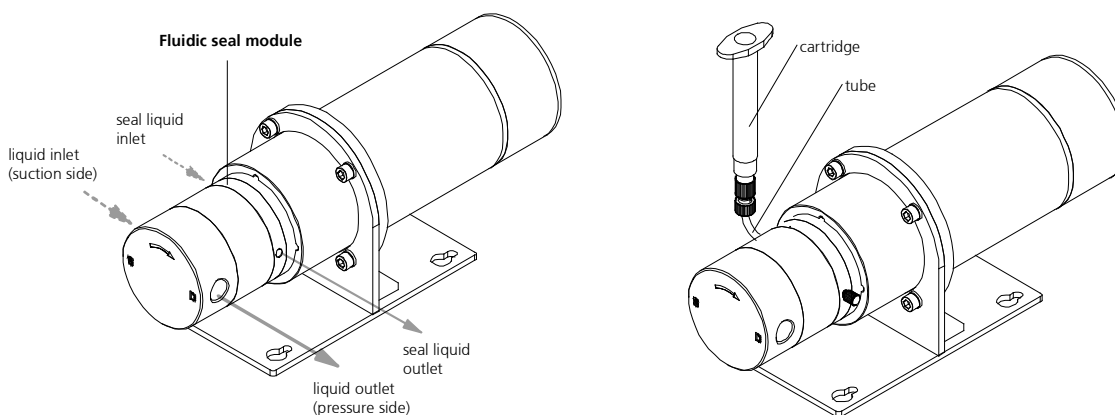

Figure 7 Design of the micro annular gear pump with fluidic seal module (example with mzs-11508)

The role of the fluidic seal module is to prevent moisture and oxygen in the surrounding atmosphere from penetrating into the pump. This eliminates the risk of unwanted chemical reaction between the atmospheric gases and the handled liquid (such as for example the crystallization reaction). The module limits at the same time the possibility for the manipulated liquids to escape from the pump.

### The function of the fluidic seal module

The shaft sealing employed in the high performance micro annular gear pump is designed in a way that allows for the formation of a boundary layer in which the delivered liquid comes into contact with the surrounding environment. Small amounts of water vapor and oxygen may penetrate through the protective boundary liquid film into the pump. The fluidic seal module enables to control this influx - only a chosen and compatible liquid may come into contact with the delivered liquid. The fluidic seal module prevents also the inverse movement of the liquid - from the pump to the environment - which could otherwise not be excluded.

With the fluidic seal module, a second sealing is added to the existing shaft sealing. A cylindrical chamber with input and output openings displaced by 180° is located between the two seals (see figure 8). When the chamber is filled with an appropriate sealing liquid, the manipulated liquid does not enter into contact with water vapor and oxygen, but dilutes at a small ratio in the sealing liquid. The dilution ratio depends on the existing pressure relations and drops with increasing viscosity.

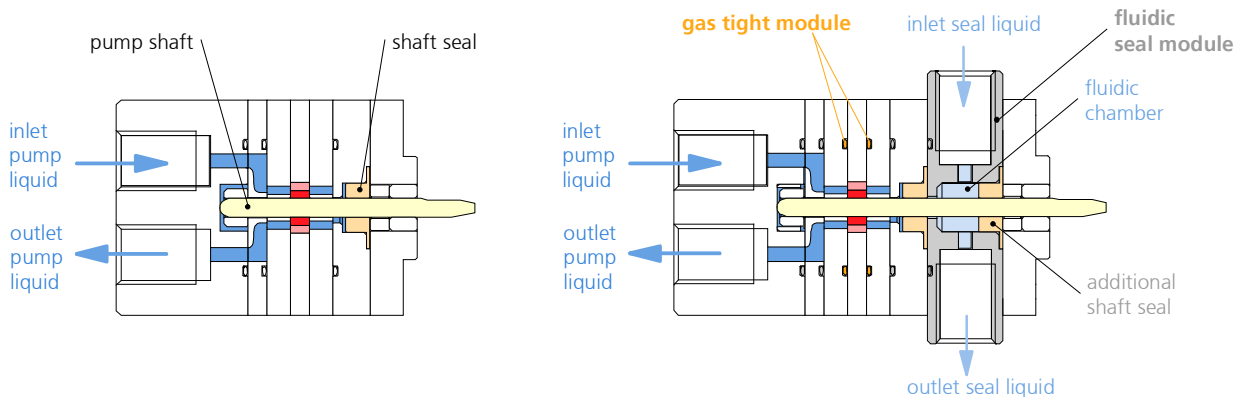

figure 8 Pump head without the fluidic seal module

Pump head with the fluidic seal module

### Pump operation with the fluidic seal module

Only liquids compatible with the delivered liquid may be used as sealing liquids. That means no liquids that could possibly react with the delivered liquid should be employed. The composition of the sealing liquid should be determined by the operator.

While filling up the fluidic seal chamber a particular attention should be paid to proper venting of the chamber through the two openings featuring a 1/4 - 28 UNF thread. These openings are slightly shifted downwards and upwards to facilitate the degassing of the sealing chamber (see figure 10). The chamber is filled through the bottom opening. The sealing liquid should be filled in so long, till it flows free of air bubbles out of the top opening. Now the inlet should be screwed down.

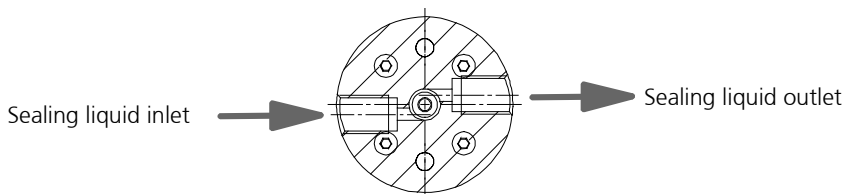

figure 9 Sectional view of the fluidic seal module

A cartridge may be used to supply the sealing liquid to the chamber (see figure 8). In special cases compressed air may be applied to the sealing liquid in order to enhance the sealing function. The sealing chamber may be flushed.



Make sure that enough sealing liquid is supplied to the fluidic seal chamber in order to prevent any penetration of air and water vapor to the module.



If the fluidic seal chamber is empty, the pump should immediately be stopped. Dry operation may lead to shaft seal damage.

In case the pump is not installed in the standard way (pump name read horizontally), it is possible to shift the outlet and inlet openings of the pump. However an appropriate supply of the sealing liquid should still be ensured and all presence of air bubbles within the fluidic seal chamber should be avoided.

### Use of the fluidic seal accessories



The fluidic seal set is mounted at the bottom inlet (see figure 9).

During assembly it is important to check if the ferrule is tightly attached to the tube and that the tube is tightly screwed to the inlet of the fluidic chamber.



figure 10

Assembly of the fluidic seal accessories (standard version)

### Liquid supply set in stainless steel version (as separate accessory)

Stainless steel liquid supply set is available on request. The use is the same as with the standard version. The liquid supply is done by a glass syringe.

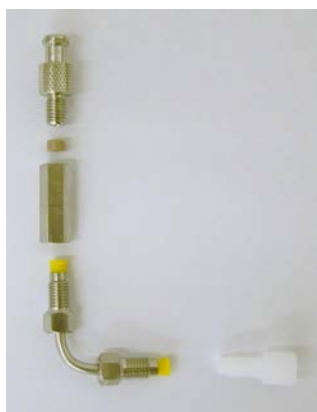

figure 11

Stainless steel set for the fluidic seal module

## 5.2 Heat insulation module

The heat insulation module enables to deliver hot liquids up to temperatures of 120° C (248 °C). It comprises thermally insulating coupling components made of plastic (PEEK) located between the pump and the drive. The drive should not be exposed to overheating. For this reason the heat transfer from the pump to the drive should be limited. An additional thermal barrier is provided by the plastic motor housing. If the surrounding temperature rises, the pump is working over a longer period or the manipulated liquid features a high temperature, convection cooling of the motor is recommended.

## 6 System integration

### 6.1 Check before installation

Inspect the pumps for potential damage during the shipment (see chapter 3.2).

Please check, if the right pump type has been delivered, as according to the following points:

- Compatibility with the delivered liquid
- Viscosity range
- Pump performance (displacement volume, dosage volumes, operating pressures)
- Operating temperature range



If you notice any difference between the required and the delivered pump type, please contact HNP Mikrosysteme. Do not put the pump into operation without prior approval.

### 6.2 Mounting of the micro annular gear pump

The micro annular gear pump is mounted on an angle support with M5 screws. The favored mounting position of the micro annular gear pump is horizontal. However, if the pump has to be operated vertically, the motor must be located above the pump head in order to prevent the liquid from entering into the motor.

#### Warning

Install the pump in such a way that in case of failure no liquid can enter the motor or controller.



Take precautions that in case of leakage no surrounding objects or environment will be damaged.



Install the micro annular gear pump only in places that fulfill the required conditions for safe pump operation.



The motor must be protected against humidity, dust or sweat.

### 6.3 General instructions for the assembly of the liquid supply network



Please always cut the tubing at a right angle with an adapted hose cutter. If metal tubes are used, an intensive cleansing procedure will be necessary. After machining the tubing has to be cleansed and flushed throughoutly. The smallest piece of swarf within the liquid delivery system may cause failure of the micro annular gear pump.



Please note that correct integration of the tubing with the pump head is a necessary condition to ensure the right direction of flow. If you wish to operate the pump in a reverse direction, please contact HNP Mikrosysteme, since it is not possible in every case.





In order to protect the interior of the pump from pollution, the pump heads are delivered with protective plugs. They should be put on when the pump is at a standstill.



For the best performance the suction tube should be as short as possible and have a large internal diameter.

**Warning**

In most cases the pump should be operated with a filter featuring pores that do not exceed 10 µm. The filter protects the pump from particles and dirt.

## 6.4 Assembly instruction for tubing and accessories

Particles or soiling can block or impair the function of the micro annular gear pump.

**Warning**

Please check that all wetted parts of the fluidic system are clean. Clean these parts in case before mounting the pump.

Please check whether there are swarfs in the screw connections, pollution remaining in reservoirs or soiling in valves, pipe work or filters.

### Assembly of the tubing and piping system

1. Please cut the tubing rectangular with a hose cutter. If metal pipes are used an intensive cleaning procedure is necessary. After machining the pipes have to be cleaned and flushed very carefully. Smallest swarfs within the fluidic system can cause failure of the micro annular gear pump.
2. Connect the fittings with the tubing respectively the pipe work according to the attached installation instruction.



Please note that the correct assembly of tubes respectively pipes with the pump head is a necessary condition to secure the right direction of flow. When you want to operate the pump in reverse direction please contact HNP Mikrosysteme since this is not possible in any application.

3. The thread of the fitting should be wrapped with 2-3 layers of PTFE tape and screwed in the NPT thread (see table 6). First manually, then tightened with ½ to ¾ wrench turns.



Clean the internal and external screw threads leaving no residues.



Make sure the internal and external screw threads are not dented or deformed.



Wrap the PTFE tape around the screw thread clockwise beginning with the second pitch of screw thread..



The PTFE tape should be wrapped tightly around the screw thread approx. 3 - 4 times.



Cut the PTFE tape off and wind the end of the tape tightly around the screw thread.



The PTFE tape should not stick out over screw thread because pieces can be cut off and get into the system.

table 5

Use of PTFE Tape

4. The suction line should be installed ascending to the pump for better degassing. The suction line should be designed as short as possible. The inner diameter of the suction line should be large to guarantee good priming of the liquid. At the planning of the pipe system take care of possibilities for degassing.
5. Operate the micro annular gear pump always with a filter with a pore size of 10  $\mu\text{m}$  or smaller. The filter prevents that particles or solids penetrate into the pump what can cause major damage.
6. Avoid dry running of the pump. Make sure that the liquid flow is not interrupted.

## 6.5 Filter selection and use

In majority of cases it is recommended to integrate a filter on the suction side of the micro annular gear pump to ensure its secure operation. The recommended filter pores or mesh size should not exceed 10 µm. The penetration of particles or swarf that could cause a blockage or damage to the pump can only be avoided by using an adapted filter.

HNP Mikrosysteme offers a choice of standard filters covering a broad spectrum of applications. You may count on our assistance for the selection of the most suitable one.

In order to select the best adapted filter, such operating parameters as flow rate, viscosity and degree of pollution of the liquid will be needed. An increase in at least one of the mentioned terms will require the use of a bigger filtering element or the pressurization of the delivered liquid. In case no suitable filter for high viscosity liquid can be found, it is possible to use a filter with slightly larger pore size. Prior discussion with HNP Mikrosysteme is here recommended. A filter with larger pores is still better than no filter at all. Alternatively an already filtered liquid may be used.

### Warning

Because filters have a large internal volume, it is recommended to fill in the filter and the suction tube with already filtered liquid in order to avoid dry operation of the pump during the startup.

### Warning

Please control regularly the filtering elements for pollution. Cleanse regularly the filter or replace it with a new one. A polluted filter may considerably decrease the volumetric efficiency of a pump. Furthermore, because of the cavitation effects dosage imprecision and even pump damage may occur.

### Warning

A too small filter (too little filtering surface) may considerably decrease the volumetric efficiency of the micro annular gear pump. What is more, because of the cavitation effects dosage imprecision and even pump damage may occur.

## 7 Motion Controller

The motion controller is integrated in the motor. Please read the separate operating instructions. The motor is preset in the parameters.



Skilled personnel may only do *mounting* and *initial operating* of micro annular gear pumps.



Check for correct polarity. False connecting may cause severe malfunction or even destroy the electronic of the motor.



*Avoid* in any case *dry running* of your *micro annular gear pump* as this may especially damage the seals.

**Filling the pump with liquid before you start the pump!**

**For filling use a syringe!**

## 8 Start Up / Shut Down

### 8.1 Preparing for operation

After the liquid supply system had been completed, please check once again the operating conditions of the micro annular gear pump as according to the following points:

- Are the inlet and outlet tubes correctly connected?
- Is the entire liquid supply system clean - that means free of particles, foreign bodies, pollution or swarf?
- Has a filter been installed on the suction side?
- Has a sufficient amount of the right liquid been supplied?
- The pump does not run the risk of a dry operation?
- The entire liquid supply system has been checked for leakage?
- Is it possible to stop the pump by an emergency switch if an unexpected malfunction occurs at the startup?

### 8.2 Startup of the micro annular gear pump

Switch on the voltage supply. The micro annular gear pump can now be put into operation by turning on the potentiometer knob or by sending a nominal external voltage signal.

Start the filling in of the pump at low or middle speed (1000 - 3000 rpm).

#### Warning

Avoid dry operation of the pump. The pump should be filled in before it is put to operation.

### 8.3 Flushing procedure after use

After each service the micro annular gear pump should be carefully flushed with a non-corrosive, filtered and particle-free flushing liquid (see table 10 and table 11). During flushing procedure the pump should operate at a speed of about 3000 rpm and if possible against a low pressure (that can be obtained by using a restrictor, a capillary or similar). The flushing liquid must be compatible with the delivered liquid and suitable for solving the remaining liquid rests. Depending on the application for example water, or isopropanol may be used. If you have doubts whether a particular liquid is suitable for this function or not, please ask the manufacturer of the liquid or HNP Mikrosysteme.

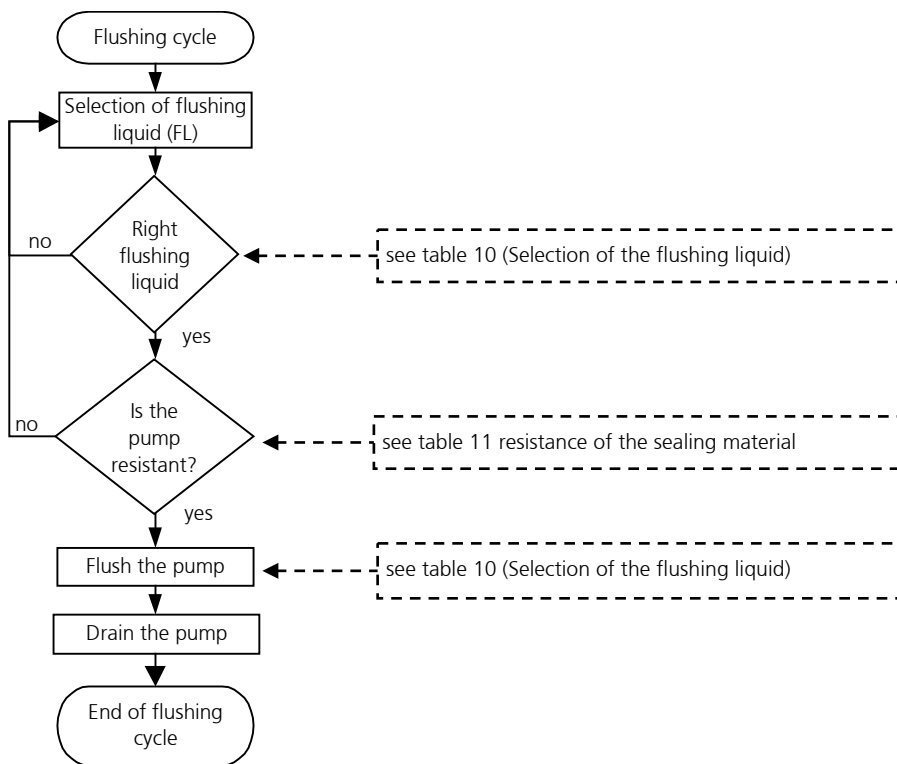

figure 12 Diagram of the flushing procedure

Warning

Liquids that remain in the pump may crystallize, coagulate or lead to corrosion and as a consequence impair the work of the micro annular gear pump.

Warning

Please make sure that the pump components and particularly O-rings and sealing are resistant to the employed flushing liquid. (see table 11).

Warning

The flushing liquid (solvent) and the recommended duration of the flushing procedure depend on the delivered liquid (see table 11). The indicated flushing liquids are simple recommendations and should therefore be checked by the user as to their compatibility and suitability.



Regulations concerning use of substances dangerous to health should be followed!

	Nature of the delivered liquid	Flushing time [min]	Suitable flushing liquid
1	Oils, fats, plastifiers	15-20	isopropanol, ethanol, acetone, benzine/petroleum ether
2	Solvents (polar + nonpolar)	5-10	isopropanol, ethanol
3	Other organic liquids	10-15	isopropanol, ethanol
4	Refrigerating and cooling agents	15-20	isopropanol, ethanol
5	Neutral water/y solutions	20-25	isopropanol, ethanol
6	Basic solutions	25-30	DI-water (deionized water)
7	Organic acids	30-40	isopropanol, ethanol
8	Weak mineral acids	25-30	DI- water
9	Strong mineral acids	35-45	DI- water
10	Strong oxidizing liquids	35-45	DI- water
11	Paints, varnishes, adhesives	50-60	not specified - for further information please contact HNP Mikrosysteme.

table 6 Selection of the flushing liquid (solvent) and the duration of the flushing procedure depending on the delivered liquid.

**Warning**

Please make sure that the pump components and particularly O-rings and sealing are resistant to the employed flushing liquid (see table 11).

Flushing liquid	Shaft sealing		O-ring material		
	PTFE (Teflon®), graphite- reinforced	UHMWPE	FPM (Viton®)	EPDM	FFPM
acetone	0	0	3	0	0
benzene	0	3	1	3	0
benzyl alcohol	0	-	0	2	0
butanol	0	-	1	0	0
dimethyl sulfoxide (DMSO)	0	0	3	0	0
ethanol	0	0	0	0	0
isopropanol	0	0	0	0	0
methanol	0	0	2	0	0
methylethylketone (MEK)	0	0	3	1	0
styrene	0	-	1	3	1
toluene	0	1	2	3	0
water	0	0	0	0	0
xylene	0	1	2	3	0
benzine/petroleum ether	0	0	0	3	0
oil / fine mechanics oil	0	0	0	3	0

Legend: 0 ... good suitability 1 ... suitability 2 ... conditional suitability 3 ... labile - ... not specified

table 7 Resistance of the sealing materials depending on the flushing liquid (solvent)

## 8.4 Shutdown of the micro annular gear pump

In order to shut down a mzf-pump the following steps should be followed:

- Flush the pump with a filtered and particle-free flushing liquid (solvent) as described in the chapter 8.3.
- After the flushing procedure decrease speed of the pump to 0 rpm
- Fill the pump with a suitable conservation liquid (see chapter 8.4.1)
- Remove the pump from the system (see chapter 8.4.2)

By proceeding as shown in the diagram (see figure 15) you may prepare the pump for a longer standstill.



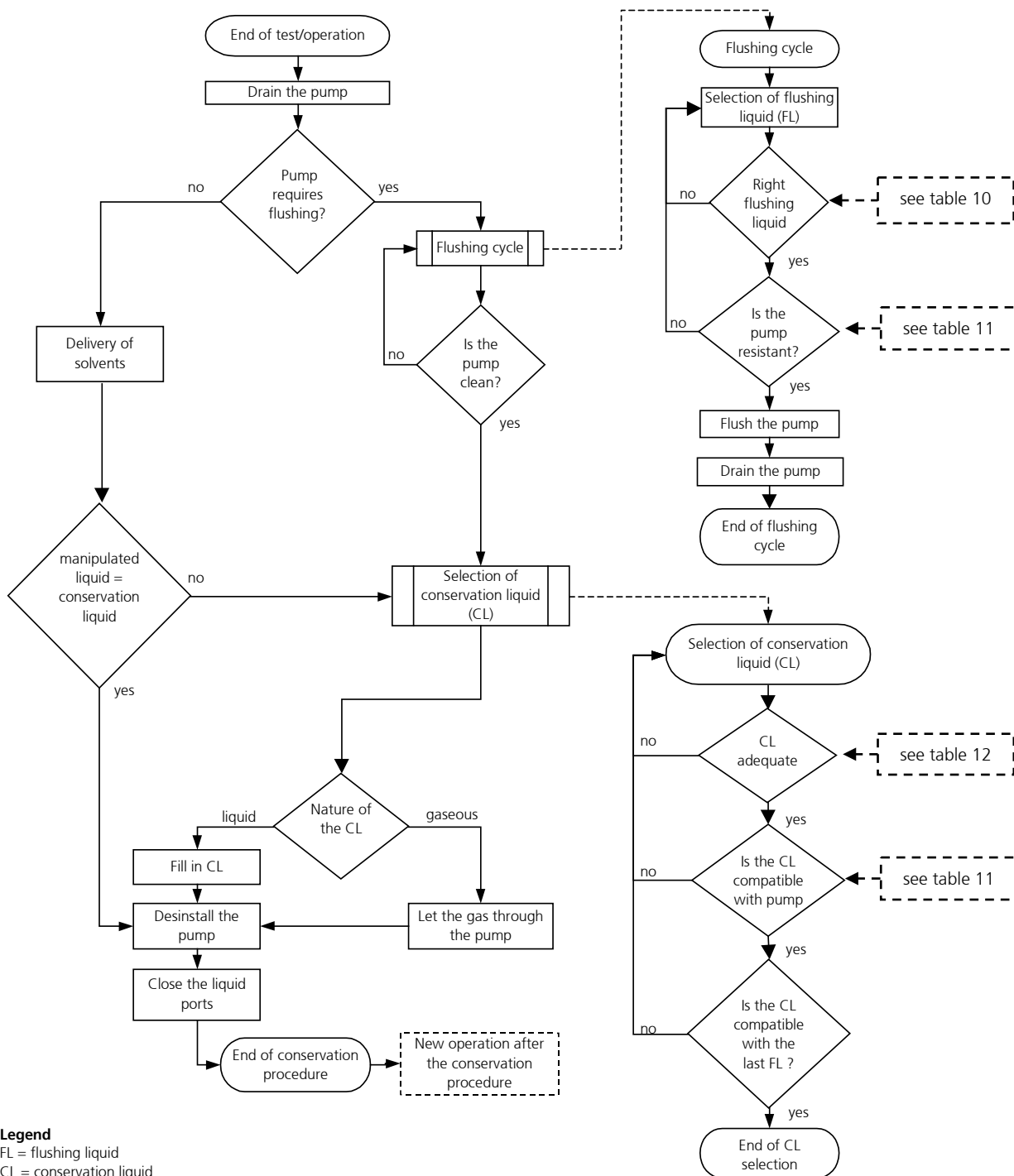

figure 13 Diagram of the shutdown procedure

### 8.4.1 Conservation

If the micro annular gear pump operates at irregular intervals or for other reasons should be put out of operation for a longer period, it should, after service and flushing procedure (see chapter 8.3), be filled in with a suitable conservation liquid.

The conservation liquid may be selected from the table 12 depending on the duration of the standstill and the resistance of the pump to the manipulated liquid. The indicated conservation liquids are simple recommendations and should therefore be checked by the user as to their compatibility and suitability. The figure 15 presents a diagram of conservation agent selection.

*Remark:* This diagram is repeated as a part of the figure 14 (shutdown procedure of the micro annular gear pump).

After the cleansing procedure the pump should be filled with a suitable conservation agent. You will find a choice of possible conservation agents in the table 12.

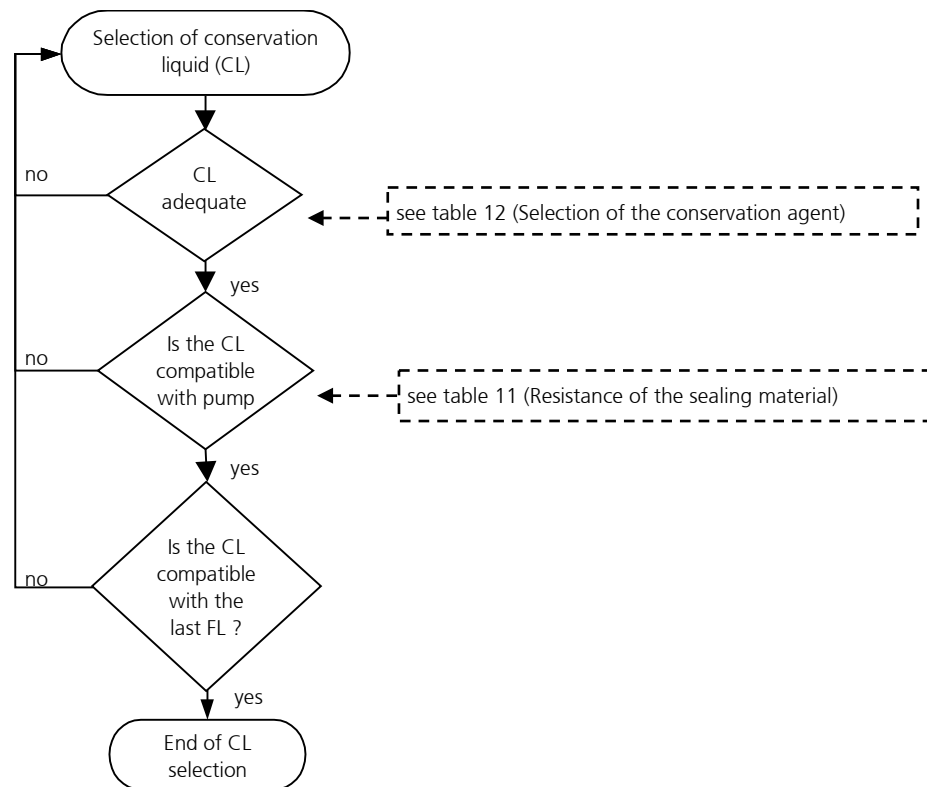

figure 14

Diagram - selection of conservation liquid (CL)

Liquids	Solubility in water	Compatibility with the delivered liquid	Duration of storage	Breakaway torque	Toxicology	Viscosity	Description
isopropanol	+	+	o	o	o	+	solvent for organic compounds, cosmetics, essential oils waxes, and esters, antifreezers, antiseptic agents
acetone	+	+	o	o	o	+	solvent for a number of organic compounds, unlimited solubility in water, dissolves natural and synthetic resins, fats, oils and commonly used plastifiers
ethanol	+	+	o	o	o	+	solvent for organic compounds, fats, oils and resins
DI-water	+	+	-	-	+	+	solvent for many organic and mineral liquids
fine mechanics oil	-	-	+	+	+	+	cleansing and protective action (dissolves fats, tar, rubber or adhesive substances, protects against corrosion).
hydraulic oil	-	-	+	+	+	-	lubricating and preserving properties ( <i>Warning</i> : may resinate or deteriorate with time)
nitrogen	-	+	+	+	o	+	is not a solvent, may leave deposits after drying out
air / compressed air		+	+	+	+	+	is not a solvent, may leave deposits after drying out

Legend: + ... good/suitable o ... satisfactory; - ... bad/inadequate

table 8 Selection of the conservation agent

In order to prevent dust particles and foreign bodies from penetrating into the pump or the conservation agent from leaking out, please secure the liquid input and output openings with the delivered protective plugs or screws.

**Warning**

Water or DI-water should not be used as conservative liquids. They germinate already after a few days and build a biofilm which can later block the pump.

#### 8.4.2 Dismantling of the system

- Put the drive out of operation by turning down speed to 0 rpm and by switching off the voltage supply. Make sure that the procedure described in the chapter 8.3 has been completed.
- Now that the pump has been stopped you may remove it from the system.
- Protect the inlet and outlet openings of the pump with adapted protective plugs or screws.

## 8.5 Trouble shooting

If the pump stops operating abruptly or has difficulties with starting operation, please undertake the following steps:

Try to liberate the micro annular gear pump:

- by turning the potentiometer knob back and forth or by connecting an analog voltage
- via the control software
- by pressing with a syringe a suitable flushing liquid (see table 10 and table 11) through the micro annular gear pump
- by changing the operating direction of the pump.

If these measures turn out to be ineffective, please contact the service staff of HNP Mikrosysteme (see chapter 17) and send the pump back to the manufacturer for inspection.

### Warning

*You should under no condition try to disassemble the pump by yourself. This may cause damage to the pump components and consequently annul your warranty claims.*

## 8.6 Return of the micro annular gear pump to the manufacturer

For the return of a micro annular gear pump and components that have already been employed, please follow the instructions:

- drain any remaining rests of the delivered liquid from the pump
- flush the pump with an adapted solvent
- remove the filter elements from integrated or loosely delivered filters
- protect all openings against dust with the delivered protective plugs or screws
- return the pump in its original packing

The service personnel which carries out the repair should be informed about the condition of the already used micro annular gear pump. This is done by means of the "Declaration of media in contact with the micro annular gear pump and its components" (see chapter 14). This form may also be downloaded from the web site [www.hnp-mikrosysteme.de/download](http://www.hnp-mikrosysteme.de/download).



The "Declaration of liquids in contact with the micro annular gear pump and its components" must imperatively be filled in. The nature of liquid which entered into contact with the micro annular gear pump and its components must be specified.

In case of non-compliance, the sender will be liable for any resulting injure to persons or any object damage.

## 9 Software » K4ConfigTool «

Please see separate manual of the motor manufacturer.

## 10 Problems and their removal

Error	Possible cause of error	Action
1 No function	No power supply	Check all power switches
2 Pump does not dose	No dosage liquid in the tank	Fill the liquid tank
	Motor error	Check motor Status of the pump with the software Motion Manager
	Dosage needle blocked	Check and clean the dosage needle
	Back-pressure valve does not work	Check the back-pressure valve
	No signal for start dosage	Check the start signal of the central control unit (PLC)
	Pump error	Replace pump and send the pump to the manufacturer
3 Pump does not prime during bringing the dosage system into service	Pump does not suck	Check of the installation
	-"-	Check air pressure on tank
	-"-	Back-pressure valve does not open, Check the back-pressure valve!
	-"-	Air bubbles in fluid system (tubings, valves)
	Tubings leak	Change the tubings
4 Motor works but pump does not pump	No liquid in pump	Prime the pump
	Air bubbles in fluid system (tubings, valves)	Prime the pump and the fluid system
	Valve not open	Flush the valve
	Dosage needle blocked	Clean, flush or change the dosage needle
	Coupling of the connection motor –pump is loose	Replace pump and send the pump to the manufacturer
	Pump shaft is broken	Replace pump and send the pump to the manufacturer
5 Pump does not pump but is filled with liquid	Particle in dosage liquid or pump blocked	Check Status of the pump with the software Motion Manager Try to get free the pump with negative prime speed (-500 rpm) for only 1 s
	-"-	Don't change the parameter of the motor with command »FCONFIG«, »LPC«, »LCC«!
	-"-	Flush the pump with the syringe
	Back-pressure valve not open	Flush the valve
	Dosage needle blockade	Clean or flush the needle
	Air bubbles in fluid system (tubings, valves)	Fill/Prime the pump and the fluid system
6 Dosage volume does not correspond with the datasheet or calculation	Air bubbles in fluid system and pump	Flush the fluid system and check the fluid system for opening connections
	Filter dirty	Change the filter
	Back-pressure valve not open	Flush the back-pressure valve
7 Liquid leaks out of the dosage needle (dosage needle drops)	Back-pressure valve not closed	Flush the back-pressure valve
	Pressure at process liquid tank	Disconnect the pressure connection of the process liquid tank
8 Liquid leaks out of the sealing liquid needle	Pressure at sealing liquid tank	Disconnect the pressure connection of the sealing liquid tank
9 Dosage volume reduces over the time	Filter dirty	Change the filter
	Dirt or deposition in the pump	Flush the pump or send the pump to the manufacturer for cleaning
10 Leak at the pump body	Seal out of order	Send the pump to inspection to the

Error	Possible cause of error	Action
		manufacturer
11 Leak of the fluid connections	Flangeless ferrules leak	Change the flangeless ferrules
12 Status of the pump cannot be checked or calibrated	No contact/connection to the pump	Check the power supply of the pump
	"-"	Check the connection of the zero modem cable between PC and dosage system or try to use a new cable
	Motor control out of order	Switch the power supply for a short time OFF and then ON to start the motor control again
13 Over temperature	Pump surface dirty	Clean the pump surface
	Pump works heavy	Flush the pump
14 Over current	Pump works heavy	Dosage needle damage, replace the needle
	"-"	Dosage needle blockade, clean or flush the needle
	Back-pressure valve not open	Flush the back-pressure valve
	Particle in dosage liquid	Flush the pump
15 Under voltage	Supply voltage < 12 VDC	Check the power supply voltage
16 Over voltage	Supply voltage > 28 VDC	Check the power supply voltage

table 9

## Trouble shooting guide



If a disturbance that has not been mentioned in the above list, or that makes the use of the micro annular gear pump unsafe appears, please stop the operation of the pump without delay and contact the manufacturer.

## 11 Accessories for microfluidic systems

The accessory range for the liquid delivery systems of HNP Mikrosysteme comprises complementary equipment such as hoses, tubes, fluid fittings, filters and non-return valves that are best adapted to your micro annular gear pump. We will eagerly share our long date experience as far as component selection is concerned.

## 12 Non-liability clause

HNP Mikrosysteme GmbH shall not be liable any damage resulting form the non-respect of instructions comprised in this operating manual.

It belongs to the user to check the integrity, the correct choice and the suitability of the product for the intended use.

It remains at the responsibility of the user to conform to all laws, rules and regulations in force. This applies above all to the treatment of aggressive, poisonous, corrosive and other dangerous liquids.

## 13 Service and maintenance

For service and maintenance, you have the possibility to send your micro annular gear pump to HNP Mikrosysteme (the address is found on the cover of this manual). In measures of the service package, seals and other parts subject to wear are exchanged.



## 14 EC Directive

A Directive or EC Directive is a legal instrument of the European Community addressing at the member states and forcing them to implement specific regulations or targets. Leastwise, micro annular gear pumps are covered, by the scope of application of the following Directives: The following directives are of importance for the user of the described micro annular gear pumps:

### **Low-Voltage Directive (2014/35/EU)**

The Low-Voltage Directive is not relevant for micro annular gear pumps described in this manual, because the supply voltage is limited to a maximum of 30 VDC.

### **Machinery Directive (2006/42/EU)**

A micro annular gear pump is a machine and is consequently covered by this Directive. However, it may be a part of a machine or installation.

### **EMC Directive (2014/30/EU)**

The Directive on Electromagnetic Compatibility (EMC) applies to all electronic and electrical devices, installations and systems. Consequently, the Motion Controller of the micro annular gear pump is covered by the EMC Directive.

### **RoHS Directive (2011/65/EU)**

To our knowledge our products delivered to you do not contain substances or applications in concentrations that are forbidden by this directive. No substances contain our products delivered to you after our current knowledge in concentrations or application, the placing on the market in products according to the valid requirements forbade to the Directive.

### **WEEE Directive (2002/96/EU)**



Disposal of micro annular gear pumps has to be environmentally sound. All materials and liquids have to be recycled in accordance with the relevant regulations. Electrical parts can not be disposed of as household waste. They have to be delivered to designated collection points.

## REACH regulation (EC) No. 1907/2006

HNP Mikrosysteme is not a manufacturer or importer of chemical substances subjected to registration, but in terms of regulation, a downstream user. As downstream user, we conduct the necessary communication with our suppliers to ensure future deliveries of all components necessary to us. We will notify you of all relevant, changes in our products, their availability and the quality of parts/products delivered by us within our business and coordinate the appropriate action in individual cases with you. Previous inspection did not show any limitation in the supply of material from our upstream suppliers.

### 14.1 Electromagnetic Compatibility (EMC)

Electromagnetic compatibility is defined as the ability of a electric or electronic device to function satisfactorily as intended in its electromagnetic environment without introducing intolerable electromagnetic disturbances in that environment.

#### 14.1.1 EMC Directive and Standards for controller S-BL

Comformity was proven by proof of compliance with the following harmonized standards by the company Dr. Fritz Faulhaber:

- EN 61000-6-4 (10/01): Generic standards – Emission standard for industrial environments
- EN 61000-6-2 (10/01): Generic standards – Immunity for industrial environments

These standards prescribe certain standardised tests for the emitted-interference and interference-immunity tests. The following tests are required due to the connections on the controller:

Generic Standard on Emitted Interference:	Description
EN 55011 (05/98)+A1(08/99)+A2(09/02):	Radio disturbance characteristics
Generic Standard on Interference Immunity	
EN 61000-4-2 (05/95)+A1(4/98)+A2(02/01):	Electrostatic discharge immunity test
EN 61000-4-3 (04/02)+A1(10/02):	Radiated, radio-frequency, electromagnetic field immunity test
EN 61000-4-4 (09/04):	Electrical fast transient/burst immunity test
EN 61000-4-5 (03/95)+A1(02/01)	Surge immunity test
EN 61000-4-6 (07/96)+A1(02/01):	Immunity to conducted disturbances, induced by radio-frequency fields
EN 61000-4-8 (09/93)+A1(02/01):	Power frequency magnetic field immunity test

Table 1

Standards Summary

All tests were conducted successfully.

### **14.1.2 Information on use as intended**

For micro annular gear pumps, note the following:  
Requirement for the intended operation is the operation according to the technical data and the manual.

#### **Restrictions**

If the micro annular gear pumps are used at home, in business or in commerce or in small businesses, appropriate measures must be taken to ensure that emitted interferences are below the permitted limit values!

## 15 Declarations of conformity

The delivered micro annular gear pump falls within scope of the following EC directives:

- Machinery Directive (2006/42/EU)
- EMC Directive (2014/30/EU)

You may request the declarations of conformity for the micro annular gear pumps from us separately.

## **EC-manufacturer's certificate (following Machinery Directive 2006/42/EC)**

We hereby declare that the following micro annular gear pumps of the modulare series:

### **mzr-11545X1**

are intended for installation into another machinery/plant and that start of operation is forbidden until it is identified that the machinery/plant into which these micro annular gear pumps shall be installed corresponds to the regulations of the EC guidelines regarding safety and health requirements.

We confirm the conformity of the product described above to the following standards in terms of applied directives

- Machinery Directive (2006/42/EC)

Applied standards are particularly

DIN EN 809	DIN EN 60204-1	DIN EN 294
DIN EN ISO 12100 part 1		DIN EN 953
DIN EN ISO 12100 part 2		UVV

This statement does not warrant any characteristics in terms of product liability. Please note the safety instructions in the manual.

Mr. Lutz Nowotka, HNP Mikrosysteme GmbH, Bleicherufer 25, D-19053 Schwerin is authorised to compile the technical file according to Annex VII A.

Date: December 30, 2017

Signature manufacturer:

Dr. Thomas Weisener  
CEO



## **EC-manufacturer's certificate (following EMC Directive 2014/30/EU)**

We hereby declare that the following micro annular gear pumps of the modulare series:

### **mzr-11545X1**

are intended for installation into another machinery/plant and that start of operation is forbidden till it is identified that the machinery/plant into which these micro annular gear pumps shall be installed corresponds to the regulations of the EC guidelines regarding safety and health requirements.

We confirm the conformity of the product described above to the following standards in terms of applied directives

- EMC Directive (2014/30/EU)

Applied standards are particularly

- |                       |   |
|-----------------------|---|
| EN 61000-6-4 (10/01): | Generic standards – Emission standard for industrial environments |
| EN 61000-6-2 (10/01): | Generic standards – Immunity for industrial environments          |

This statement does not warrant any characteristics in terms of product liability. Please note the safety instructions in the manual.

Date: December 30, 2017

Signature manufacturer:

Dr. Thomas Weisener  
CEO





## 16 Service, maintenance and warranty.

The maintenance of the micro annular gear pump should be carried out depending on the delivered liquid

- *for lubricating liquids* after 12,000 h working hours, but not later than 24 months after the initial operation
- *for non-lubricating liquids, crystallizing liquids or liquids containing particles*, after 5000 h working hours but not later than 12 months after the initial operation. If during the first inspection no substantial wearout of the pump is observed, the following inspection under the same working conditions should be performed after 8000 h working hours, yet not later than 15 months following to the last inspection.

If during the first inspection the pump shows a particularly strong wearout, the maintenance intervals should be readapted to the operating parameters.

In order to prevent a strong wearout of the pump, the pump should be shut down properly after every application as described in the chapter 8.4. A supplementary flushing procedure with a neutral flushing liquid (see chapter 8.3) also slows down the wearout process of the pump.



It is not allowed to open the micro annular gear pumps. The warranty extinguishes with the expiry of the legal warranty period or with the opening of the pump. Furthermore HNP Mikrosysteme cannot give any warranty of exchange for parts whose damage result from incorrect use.



For service and maintenance please return your micro annular gear pump to HNP Mikrosysteme (You will find the address on the cover of the present operating manual).



The declaration of liquids having had contact with the micro annular gear pump and components must imperatively be completed. The nature of the liquids must be specified. In case of non-compliance the sender will be liable for any resulting injure to persons or any object damage.



Sealings, rotors and shaft are parts that undergo wear and will be replaced by HNP Mikrosysteme GmbH during maintenance depending on their degree of wear.

## 17 Contact persons

### **Development and application assistance , service and accessories**

Mr. Sven Reimann  
Phone +49| (0) 385|52190-349

### **Service and maintenance**

Mr. Steffen Edler  
Phone +49| (0) 385|52190-307

### **Drive and control technology**

Mr. Lutz Nowotka  
Phone +49| (0) 385|52190-346

## 18 Legal information

### Marks

mzr® is a registered German trademark of HNP Mikrosysteme GmbH.

MoDoS® is a registered German trademark of HNP Mikrosysteme GmbH.

µ-Clamp® is a registered German trademark of HNP Mikrosysteme GmbH.

HNPM® is a registered German trademark of HNP Mikrosysteme GmbH.

Teflon® is a registered trademark of DuPont.

Viton® is a registered trademark of DuPont Dow Elastomers.

Kalrez® Spectrum™ is a registered trademark of DuPont.

PEEK™ is a registered trademark of Victrex plc.

HASTELLOY® is a registered trademark of Haynes International, Inc.

Aflas® is a registered trademark of ASAHI Glass Ltd.

Microsoft®, Windows® are registered trademarks of Microsoft Corporation in the USA and in the other countries.

Cavro® is a registered trademark of Tecan Systems, Inc.

Other product names or descriptions not mentioned above are possibly registered trademarks of related companies.

### Patents

Micro annular gear pumps (and housings) are protected by assigned patents: EP 1115979 B1, US 6,520,757 B1, EP 852674 B1, US 6,179,596 B1, EP 1354135, US 7,698,818 B2. Patents pending DE 10 2011 001 041.6, PCT/IB2011/055108, EP 11 81 3388.3, US 13/884,088, CN 2011 8006 5051.7, HK 13 11 2934.9, DE 10 2011 051 486.4, PCT/EP2012/061514, EP 12 728264.8, US 9,404,492 B2, CN 2012 8003 8326.2. In the US, Europe and China additional patents are pending.

## 19 Safety information for the return of already employed micro annular gear pumps and components

### 19.1 General information

The operator carries the responsibility for health and safety of his/her employees. The responsibility extends also to employees not belonging to the company that have a direct contact with the micro annular gear pump and its components during repair or maintenance works. The nature of media (liquids) coming into contact with the micro annular gear pump and its components must be specified in the corresponding declaration form.

### 19.2 Declaration of liquids in contact with the micro annular gear pump

The staff performing the repair or maintenance works must be informed about the condition of the micro annular gear pump before starting any work on the device. The »Declaration of media in contact with the micro annular gear pump« should be filled in for this purpose.

The declaration should be sent directly to the supplier or to the company designated by the supplier. A second copy of the declaration must be attached to the shipment documents.

### 19.3 Shipment

The following instructions should be observed for the shipment of the micro annular gear pump.

- drain any remaining liquid from the pump
- flush the pump with an adapted flushing liquid
- remove the filter elements from the integrated or loosely delivered filters
- all the openings should be air-tight plugged
- return the pump in the original packing

## 20 Declaration of media in contact with the micro annular gear pump and its components

### Type of the device

Pump type/article no.: \_\_\_\_\_  
Serial number: \_\_\_\_\_  
Operating hours/running time: \_\_\_\_\_  
Reason of return: \_\_\_\_\_  
\_\_\_\_\_  
\_\_\_\_\_

### Contact with media (liquids)

The micro annular gear pump was in contact with: \_\_\_\_\_

and has been rinsed with: \_\_\_\_\_

Product info sheet / Material Safety Data Sheet:  yes\*  no \* Please attach file

or is available on the following web site: www. \_\_\_\_\_

If a pump which had contact with dangerous substances could not be properly cleansed prior to shipment, we reserve the right to entrust a specialized company with cleansing of the device. The return of the pump in original packing is advisable. It is necessary in order to protect the employees and delivery staff.

Nature of media contact:

<input type="checkbox"/> explosive	<input type="checkbox"/> oxidizing	<input type="checkbox"/> sensitive to moisture
<input type="checkbox"/> toxic (toxic byproducts)	<input type="checkbox"/> radioactive	pH-value: approx. _____ to _____
<input type="checkbox"/> carcinogenic	<input type="checkbox"/> microbiological	other: _____
<input type="checkbox"/> irritant	<input type="checkbox"/> corrosive	_____

Hazard (H-statements): \_\_\_\_\_ Precautionary (P-statements): \_\_\_\_\_

### Declaration

Hereby I/we affirm that the stated information is complete and correct. Micro annular gear pump and accessories are shipped in conformity with the applicable regulations.

company: \_\_\_\_\_  Mrs  Mr title: \_\_\_\_\_  
division: \_\_\_\_\_ name: \_\_\_\_\_  
street, no.: \_\_\_\_\_ phone: \_\_\_\_\_  
ZIP/city: \_\_\_\_\_ e-mail: \_\_\_\_\_  
country: \_\_\_\_\_

city, date: \_\_\_\_\_ authorized signature /  
company stamp:

## 21 Supplement

– Drawings

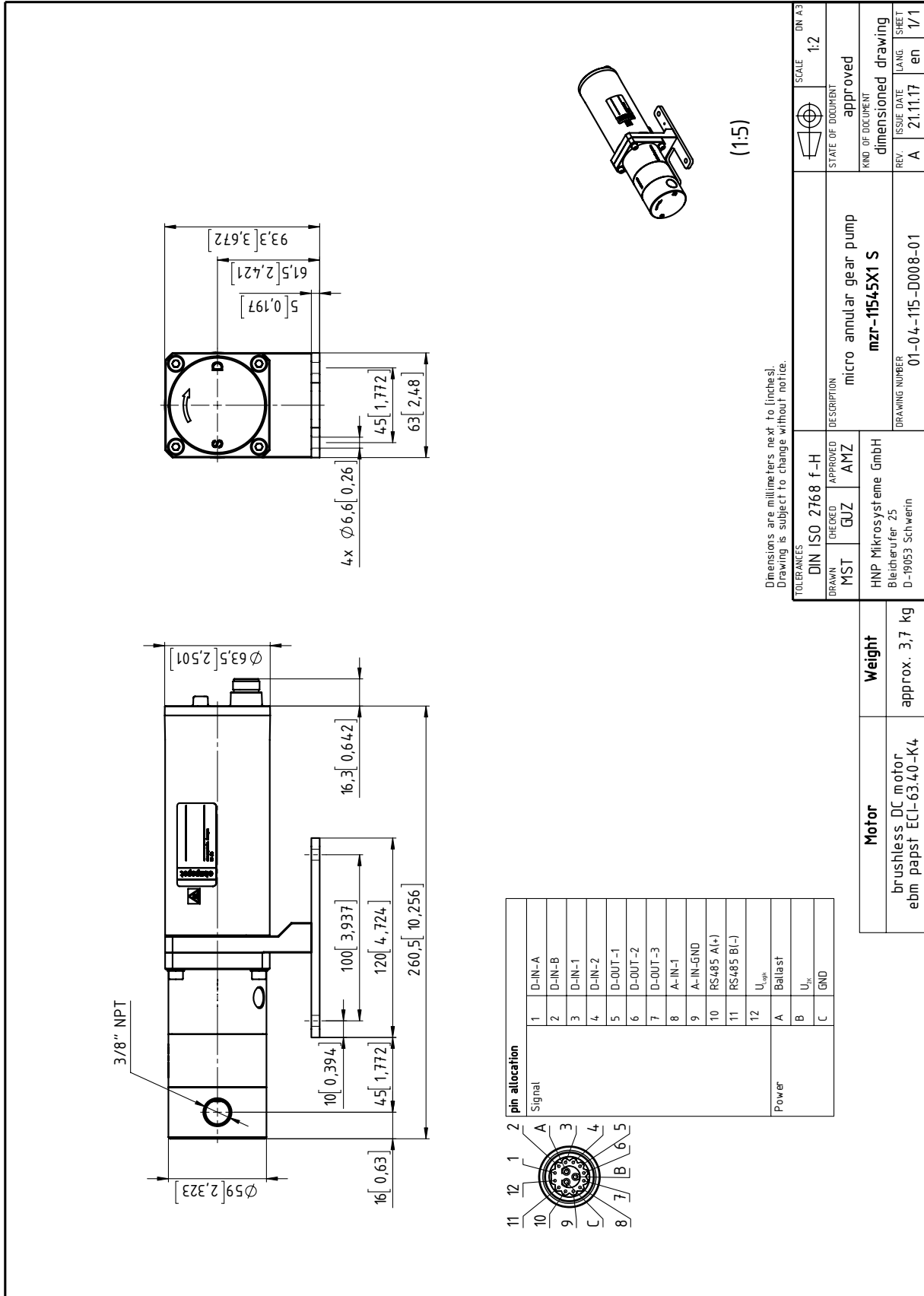

pin allocation	
1	D-IN-A
2	D-IN-B
3	D-IN-1
4	D-IN-2
5	D-OUT-1
6	D-OUT-2
7	D-OUT-3
8	A-IN-1
9	A-IN-GND
10	RS485 A(+)
11	RS485 B(-)
12	U <sub>opp</sub>
Power	
A	Ballast
B	U <sub>bc</sub>
C	GND

(1.5)

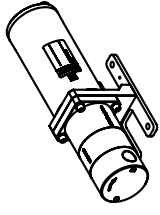

Dimensions are millimeters next to [inches].  
Drawing is subject to change without notice.

TOLERANCES		DIN ISO 2768 f-H		SCALE		DIN A3	
DRAWN	CHECKED	APPROVED	STATE OF DOCUMENT	approved	1:2		
MST	GUZ	AMZ	DESCRIPTION	micro annular gear pump			
HNP Mikrosysteme GmbH				KIND OF DOCUMENT			
Bleithaler 25				dimensioned drawing			
D-19053 Schwerin				REV.	ISSUE DATE	LANG.	SHEET
				A	21.11.17	en	1/1
				DRAWING NUMBER			
				01-04-115-D008-01			

<b>Motor</b>	<b>Weight</b>
brushless DC motor ebm papst ECI-63.40-K4	approx. 3,7 kg

germanidat an 21111725303

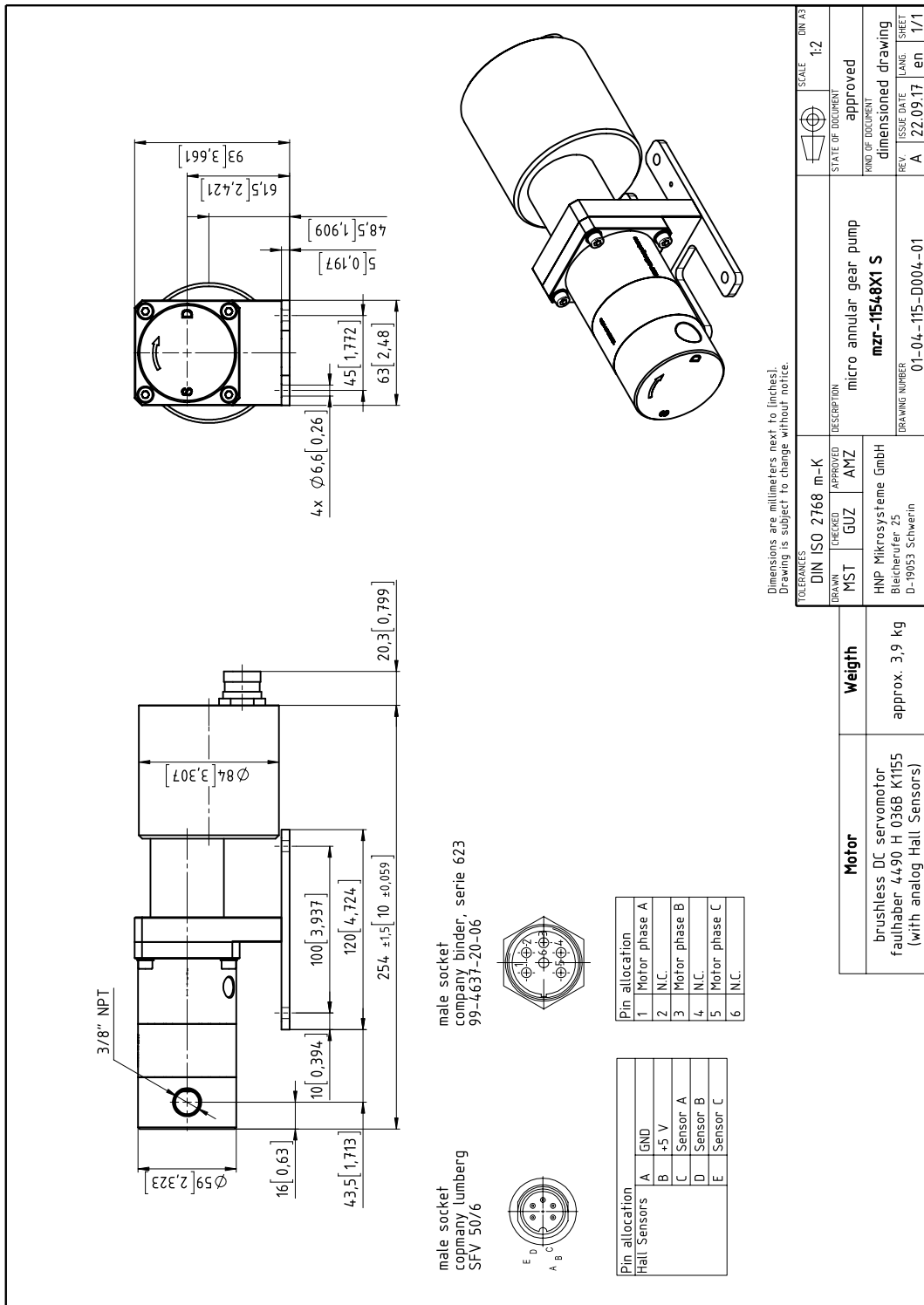

TOLERANCES	DIN ISO 2768 m-K	SCALE	1:2
DRAWN	MST	STATE OF DOCUMENT	approved
CHECKED	GUZ	DESCRIPTION	micro annular gear pump
APPROVED	AMZ	KIND OF DOCUMENT	dimensioned drawing
HNP Mikrosysteme GmbH Bleichstr. 25 D-19053 Schwerin		REV	ISSUE DATE
DRAWING NUMBER		REV	ISSUE DATE
01-04-115-D004-01		A	22.09.17
		LANG	en
		SHEET	1/1

<b>Motor</b>	brushless DC servomotor fauthaber 4490 H 036B K1155 (with analog Hall Sensors)
<b>Weight</b>	approx. 3,9 kg