

## Operating manual for micro annular gear pump **mzr-6355 and mzr-7255**



HNP Mikrosysteme GmbH  
Bleicherufer 25  
D-19053 Schwerin  
Phone: 0385/52190-301  
Fax: 0385/52190-333  
E-mail: [info@hnp-mikrosysteme.de](mailto:info@hnp-mikrosysteme.de)  
<http://www.hnp-mikrosysteme.de>

Last update: November 2024

## **Impressum**

Original instructions

Copyright

HNP Mikrosysteme GmbH  
Bleicherufer 25  
D-19053 Schwerin

All rights, including translation, reserved.

Without prior explicit written permission of HNP Mikrosysteme GmbH no part of this manual may be, copied, reproduced or processed.

This manual has been prepared with care. HNP Mikrosysteme does assume no liability for any errors in this manual and resulting consequences. Likewise, no liability is assumed direct or subsequent damages arising from an incorrect use of the devices.

While using micro annular gear pumps, the relevant standards regarding the specifications of this manual have to be followed.

Subject to change without notice.

# Contents

<b>1</b>	<b>General information</b>	<b>1</b>
1.1	Application scope of the pumps	1
1.2	Product information	2
1.3	Technical data of the micro annular gear pumps	2
1.4	Measurements and flow chart of the m zr-6355 pump	4
1.5	Measurements and flow chart of the m zr-7255 pump	5
1.6	Technical data of the drive 3564K024BCS	6
<b>2</b>	<b>Safety instructions</b>	<b>8</b>
2.1	Staff qualification and training	8
2.2	Safety-conscious work	8
2.3	Safety instructions for the operator	9
2.4	Safety instructions for maintenance, check and assembly of the pump	9
2.5	Unauthorized pump conversions and spare part manufacture	10
2.6	Improper modes of operation	10
2.7	General safety instructions	10
<b>3</b>	<b>Transport and intermediate storage</b>	<b>11</b>
3.1	Shipment of the pumps and protection measures	11
3.2	Transport	11
3.3	Intermediate storage	11
<b>4</b>	<b>Description of the micro annular gear pump</b>	<b>12</b>
4.1	Operating principle of the micro annular gear pump	12
4.2	Construction	14
4.3	Construction materials	15
4.4	Liquid supply	16
<b>5</b>	<b>Optional modules</b>	<b>17</b>
5.1	Thermal insulation module	17
5.2	Heating module	18
5.2.1	Electric heating module	18
5.3	Heating device „JETmicro“	19
5.4	Heating device „JETmini“ (new)	20
<b>6</b>	<b>System integration</b>	<b>23</b>
6.1	Check before the first assembly	23
6.2	Mounting of micro annular gear pump	23
6.3	General instructions for the assembly of the liquid supply network	24
6.4	Assembly of the fluid connection fittings	24
6.5	Changing pump head	26
6.5.1	Steps	27
6.6	Filter selection and use	29

6.7	Connection of the micro annular gear pump to the power supply	30
6.7.1	Startup with potentiometer	32
6.7.2	Startup with external 0-10 V signal	33
6.7.3	Startup with an external 0(4)-20 mA current signal	34
6.7.4	Startup with external potentiometer	36
6.7.5	Startup with the RS-232 interface	37
6.7.6	Startup of the pump units with network mode (NET1 Command)	38
6.8	Connection of the micro annular gear pump with terminal box S-G05 with screw clamp terminal	40
<b>7</b>	<b>Startup/shutdown of a mzr-pump</b>	<b>42</b>
7.1	Preparing for operation	42
7.2	Startup of the micro annular gear pump	42
7.3	Flushing procedure after use	42
7.4	Shutdown of the micro annular gear pump	45
7.4.1	Conservation	47
7.4.2	Dismantling of the system	48
7.5	Trouble shooting	49
7.6	Return of the micro annular gear pump to the manufacturer	49
<b>8</b>	<b>Software »mzr-pump controller«</b>	<b>50</b>
<b>9</b>	<b>Software »Motion Manager«</b>	<b>52</b>
9.1	Direct drive control	52
9.2	Programming of the control	54
9.3	Transfer of a mcl file to the drive	54
<b>10</b>	<b>Accessories for microfluidic systems</b>	<b>57</b>
<b>11</b>	<b>Non-liability clause</b>	<b>57</b>
<b>12</b>	<b>Problems and their removal</b>	<b>58</b>
<b>13</b>	<b>EU Directive</b>	<b>61</b>
13.1	Electromagnetic Compatibility (EMC)	62
13.1.1	EMC Directive and Standards	62
13.1.2	Information on use as intended	63
<b>14</b>	<b>Declarations of conformity</b>	<b>64</b>
<b>15</b>	<b>Service, maintenance and warranty</b>	<b>69</b>
<b>16</b>	<b>Contact person</b>	<b>70</b>
<b>17</b>	<b>Legal information</b>	<b>71</b>

<b>18</b>	<b>Safety information for the return of already employed micro annular gear pumps and components</b>	<b>72</b>
18.1	General information	72
18.2	Declaration of liquids in contact with the micro annular gear pump	72
18.3	Shipment	72
<b>19</b>	<b>Declaration of media in contact with the micro annular gear pump and its components</b>	<b>73</b>
<b>20</b>	<b>Appendix</b>	<b>74</b>



# 1 General information

This operation manual contains basic instructions to be followed during integration, operation and maintenance of a mzr® micro annular gear pump. For this reason it is necessary to read it carefully before any handling of the device. The present manual should always be kept at the operation site of the micro annular gear pump.

In case assistance is needed, please indicate the pump type visible on the housing.

## 1.1 Application scope of the pumps

The micro annular gear pumps described in this manual are suitable for continuous delivery and discrete dosage of water, watery solutions, solvents, methanol, oils, lubricating liquids, paints and varnishes as well as many other liquids.



If you intend to treat any poisonous or radioactive liquids, you must conform to safety measures as according to the regulations in force. Any project concerning handling of corrosive liquids should be previously discussed with the pump manufacturer.



The micro annular gear pumps *must not* be used for invasive medical applications, in which the liquid having had contact with the pump is re-introduced to the body.



Micro annular gear pumps exclusively are provided for use in the industrial area. A private use is excluded.



The micro annular gear pumps *must not* be used in aircrafts and spacecrafts or other vehicles without prior consent of the manufacturer.



Data concerning resistance of the pumps to the manipulated liquids have been elaborated according to the best of HNPM's knowledge. However, operating parameters varying from one application case to another, no warranty for this information can be given.



Information given in this manual does not release the customer from the personal obligation to check the integrity, correct choice and suitability of the pump for the intended use. The use of the micro annular gear pumps should be conform with technical norms and regulations in force.

If you wish to receive more information than comprised in this manual please contact directly HNP Mikrosysteme.

## 1.2 Product information

The present operating manual is valid for the micro annular gear pump types mzr-7255 manufactured after 2006 and mzr-6355 manufactured after 2009 by HNP Mikrosysteme GmbH, Bleicherufer 25, D-19053 Schwerin, Germany.

The date of release of the present manual figures on the cover.

## 1.3 Technical data of the micro annular gear pumps

		mzr-6355	mzr-7255
<b>Technical data</b>			
Displacement volume [μl]		24	48
Measurements [mm]	L x B x H	146 x 70 x 72	146 x 70 x 72
Weight [g]		1650	1650
Internal volume [μl]		524	525
Material	different combination -cy, -cs, -hy, -hs (see chapter 4.3)	●	●
Threaded fluid supply connections	1/8" NPT (lateral)	●	●
Coupling	magnetic coupling	●	●
<b>Performance parameters</b>			
Flow rate Q [ml/min]	min.	0.024	0.048
	[ml/min]	max.	144
	[l/h]	max.	8,64
Min. dosage volume [μl]		15	30
Max. system pressure [bar]	inlet pressure+differential pressure	80 (1160 psi) for -cy, -hy 60 (870 psi) for -cs, -hs for pump made of 316L	
Differential pressure range [bar]	by viscosity 1 mPas	5 (-hx) (72 psi) 15 (-cx) (217 psi),	15 (-dcx) (217 psi), 20 (-cx) (290 psi) 30 (-hx) (435 psi)
	by viscosity 16 mPas	40 (580 psi)	40 (580 psi)
Viscosity η [mPas]	min.	0.3	0.3
	max.	1,000	1,000
Dosage precision CV [%]		<1	<1
Pulsation [%]		1,5	6
NPSH <sub>R</sub> -value [m]	min.	0.5	0.5
Liquid temperature [°C]	min.	-5	-5
	max.	60	60
		-cs max 100 * -hs max 150 *	-cs max 100 * -hs max 150 *
Ambient temperature [°C]	min.	-5	-5
	max.	60	60
Storage temperature [°C]	min.	-5	-5
	max.	40	40

Legend: ● available      CV Coefficient of variation  
 ⊙ optional / on demand      NPSH<sub>R</sub> Net Positive Suction Head Required  
 – not available  
 \* with supplementary modules

table 1

Technical data and performance parameters of the micro annular gear pumps mzr-6355 and mzr-7255

**Warning**

The material properties of a liquid (e.g. viscosity, lubricating property, particle content, corrosiveness) impacts the technical data and the lifetime of pumps. Under appropriate conditions the characteristic values may be increased or decreased.

**Warning**

If you intend to operate the pump out of the range of the above given specification, please consult the manufacturer. Modifications may be necessary to ensure successful operation. Otherwise the pump or the system may be damaged seriously.

**Warning**

The manufacturer of the pump cannot guarantee the fatigue strength of the pump case due to the unknown load impact defined by different specification parameters like type of liquid, concentration, temperature. The cause for this restriction is a non predictable corrosion at the pump case like pitting, micro cracking and surface erosion which causes a wall thickness reduction and an increase of the notch effect. This could reduce the fatigue strength limit considerably. Under a particularly aggressive environment only a time dependent stability can be assumed. Because of the mentioned above the manufacturer cannot give specifications concerning the number of possible load alternations.

**Warning**

Water or DI water is not suitable for continuous operation or for commissioning with the material combinations -cs and -cy.

Water can be used for flushing and cleaning. Noise development is to be expected. Operation of the pumps with the material combination -cs or -cy with water at low speed leads to stick-slip effects in the rotor set and strongly fluctuating motor current consumption up to the automatic switch-off of the pump by occurring overcurrent conditions.

If necessary, a customer advisor at HNPM should be consulted.

<https://www.hnp-mikrosysteme.de/en/contact/technical-sales/>

### 1.4 Measurements and flow chart of the mzr-6355 pump

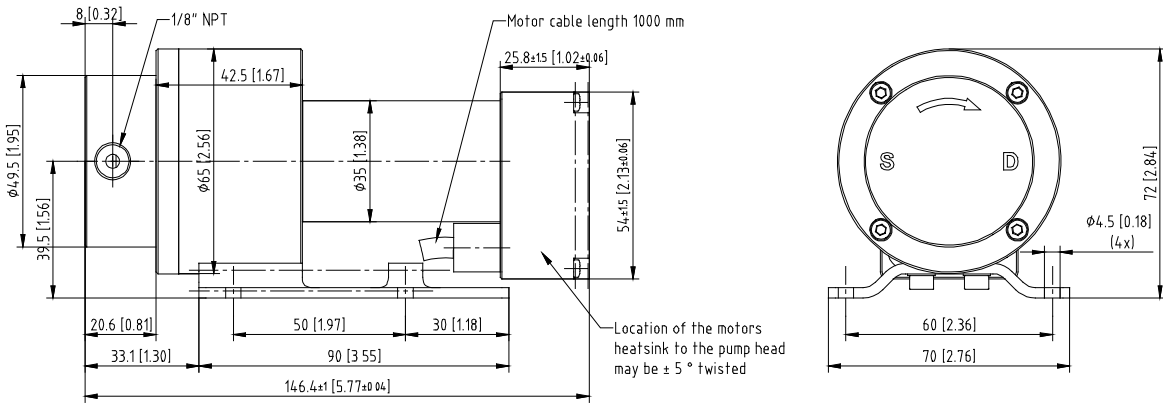

figure 1 Measurements of the micro annular gear pump mzr-6355 with lateral fluid connection 1/8" NPT

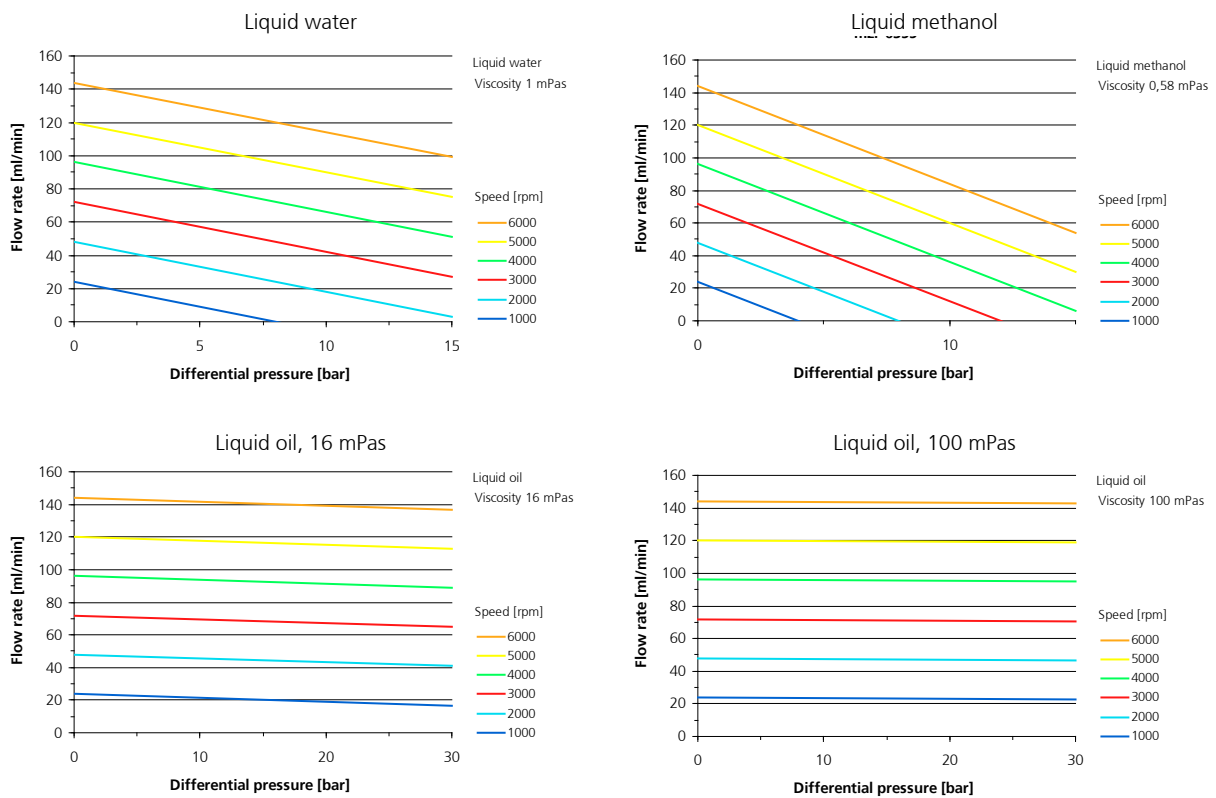

figure 2 Flow charts of the mzr-6355 pump

### 1.5 Measurements and flow chart of the mzs-7255 pump

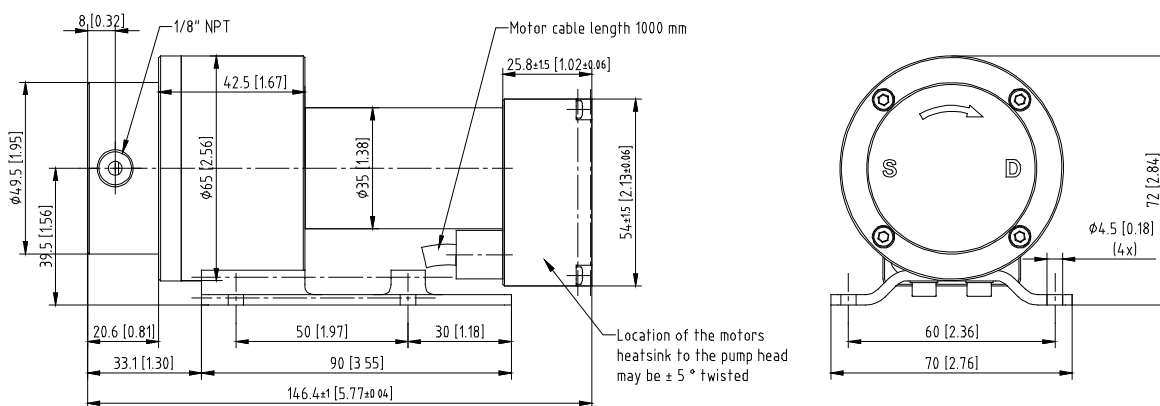

figure 3 Measurements of the micro annular gear pump mzs-7255 with lateral fluid connection 1/8" NPT

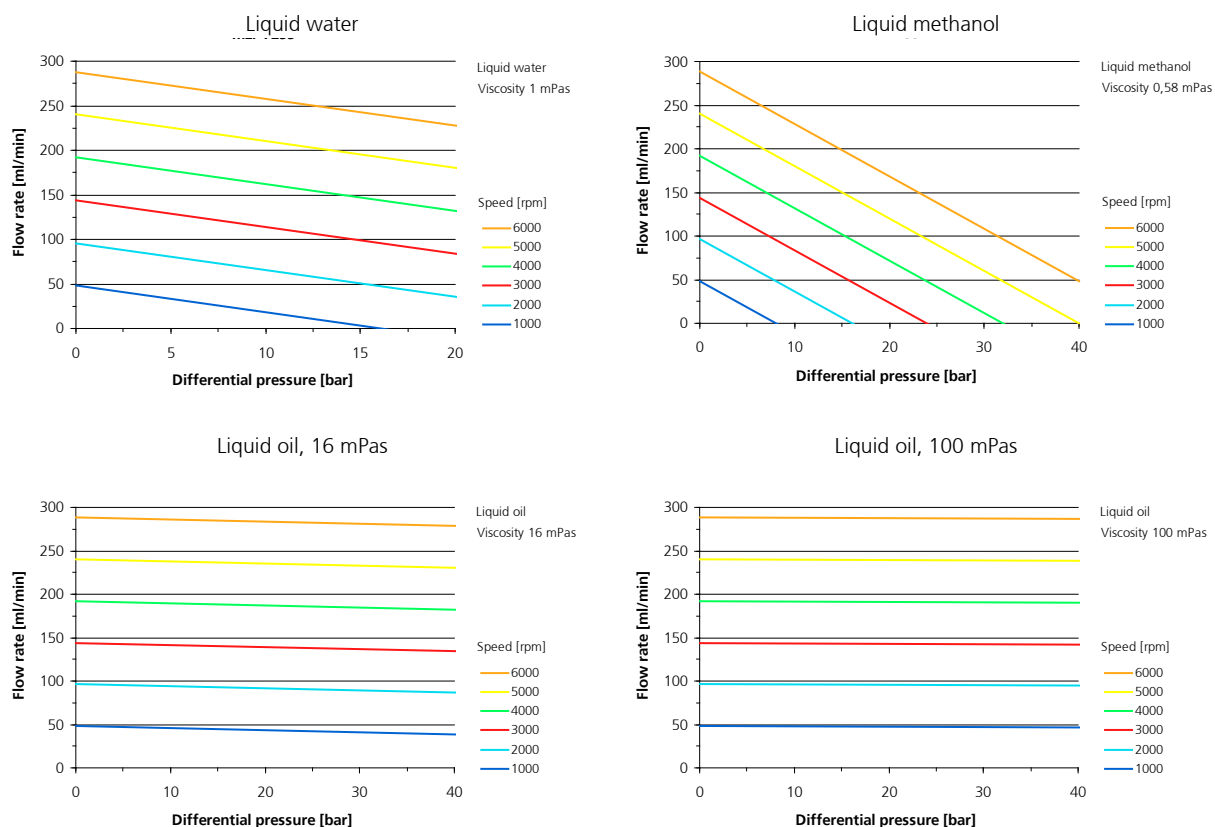

figure 4 Flow charts of the mzs-7255 pump

## 1.6 Technical data of the drive 3564K024BCS

The micro annular gear pump is driven by electronically commutated, brushless motors with integrated control. The control unit is composed of a 16-bit microcontroller and power electronics. It enables to adjust both speed and position of the motor. The motor is highly dynamic and suitable for dosing tasks performed by the micro annular gear pump. CDs or diskettes containing software running under Windows® which permits to set the parameters, as well as to program and control the pump are included in the package. The package contains also a user-friendly terminal box and a null-modem cable for an easy connection to the serial port of a PC.

Performance characteristics of the motor	
Motor type	3564K024BCS
Nominal voltage $U_B$	24 VDC
Supply voltage	12 – 30 V
Residual ripple	≤ 2 %
Max. continuous current	2.8 A
Max. peak current	8 A
Power	44 W
Max. continuous torque	50 mNm
Counts per turn	1000 (3000*)
Speed range	1 – 6000 rpm
Max speed at 24 V	9000 rpm
Input No. 1 (speed input)	0 – 10 V
Resistance input No. 1	18 kΩ
Fault output (input No. 2)	Open collector max. $U_B$ / 30 mA no error: switched to GND programmed as an input: low 0...0.5 V / high 4 V... $U_B$
Digital input No. 3	low 0...0.5 V / high 4...30 V
Serial port	RS-232
Protection class	IP 44
Connection cable length	1 m

Legend: \* with special programming

table 2

Technical data for the drive of micro annular gear pumps mzr-6355 and mzr-7255

Wire	Description
blue	GND
pink	+24 V
brown	Analog input
white	Fault output
gray	Analog GND
yellow	RS-232 RXD
green	RS-232 TXD
red	Digital input

table 3 Pin configuration of the motor

Motor current parameters	mzr-6355	mzr-7255
Peak current LPC [mA]	4000	4000
Continuous current LCC [mA]	2000	2500
Max. speed SP [rpm]	6000	6000
Acceleration AC [rotation/s <sup>2</sup> ]	400	400

table 4 Programmed current and acceleration parameters at the delivery of standard pumps

pin plug / socket	Description
1	GND
2	analog input
3	+24 V
4	fault out
5	analog GND
6	RS-232 RxD
7	RS-232 TxD
8	digital Input 3

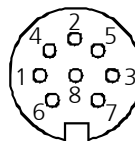

table 5 Pin configuration of the optional lengthening cable

## 2 Safety instructions

Please comply not only with the general safety instructions listed below, but also with specific safety instructions mentioned in the following chapters.

Non respect of the safety instructions marked with the following signs represents danger to *people*:

Danger symbol



Safety symbol according to  
DIN 4844 – W9

High voltage symbol



Safety symbol according to  
DIN 4844 – W8

Non compliance with the safety instructions marked with the following sign:

Warning

represents a risk of damage to the *micro annular gear pump*.

Operating instructions machined directly on the pump such as the indication of liquid input and output should be followed and kept in a clearly readable condition.

### 2.1 Staff qualification and training

The staff operating, servicing, inspecting and assembling the pumps must evidence the appropriate qualification for these works. Areas of responsibility and competence as well as monitoring of the staff must be precisely regulated by the decision maker. If the personnel do not have the necessary knowledge, they must be trained and instructed accordingly. If necessary, this can be implemented by the supplier or the manufacturer on behalf of the operator. Furthermore, the operator in charge must ensure that the content of the present manual has been fully understood by the personnel.

### 2.2 Safety-conscious work

The safety instructions listed in this operating manual, applicable national regulations concerning accident prevention as well as internal work, operation and safety regulations of the operator must be complied with.

## 2.3 Safety instructions for the operator

The surface temperature of the motor under full load may exceed 60°C. If needed, this surface should be protected on site against contact in order to avoid skin burns.

The drive should be protected against dust, water vapor condensation, humidity, splash water, aggressive gases and liquids. Please provide for adequate air ventilation and thus cooling of the motor.

The micro annular gear pumps mzr-6355 und mzr-7255 must not be used in areas exposed to explosion risks or in the proximity of inflammable gases and vapors.

Possible leaks of dangerous liquids (for example from the shaft sealing) should be guided away in a way not to represent any danger for the personnel and the environment. The pump should be regularly checked for possible leakage. All legal requirements in this matter should be followed.

Take care that all risks resulting from the electric energy are excluded. (For details please refer to the instructions provided by the authorities in charge or your power supplier.)

**Warning**

Please insure, that the totality of the liquid supply accessories such as tubes, hoses, filters etc. are free from dust or dirt particles. Impurities such as metal, plastic or glass particles may impair or damage the pump leading to its failure.

**Warning**

Please, operate the pump with a filter featuring 10 µm or smaller pores. It will protect the pump.

## 2.4 Safety instructions for maintenance, check and assembly of the pump

As a rule all maintenance work on the device should be performed when the device is at a standstill. The shutdown procedure described in this manual must be followed. Pumps delivering liquids hazardous to health must be decontaminated. Immediately after the work had been completed all safety equipment and protection measures should be applied.

Before starting the operation, please take into notice the instructions listed in the chapter 6.7.

**Warning**

Should a malfunction of the pump occur, do not dismantle the pump on your own but contact one of HNP Mikrosysteme's service staff for professional assistance.

## 2.5 Unauthorized pump conversions and spare part manufacture

Conversions or modification to the device are only permitted with prior consent of the manufacturer. Original spare parts and accessories authorized by the manufacturer ensure safety. The use of other parts will annul the liability of the pump manufacturer for any resulting consequences.

## 2.6 Improper modes of operation

The safety of operation of the delivered device can only be insured by correct use, as described in chapter 1. The limit values given in this manual must not be exceeded in any case.

## 2.7 General safety instructions

Please observe the following safety instructions



The pump may operate at high pressures. For this reason please use only the delivered accessories and ensure that the employed fittings and tubing have been prescribed and approved for these pressures.



In order to decrease the pressure, provide the system with a *pressure control valve* directing the excess liquid to the storage tank or back to the suction side. In the case of blockage of the pressure side the operating pressure can multiply, this can lead to the damage of downstream components.



At a standstill, the liquid may flow through the pump in the direction of the falling pressure. In order to avoid this unwanted movement, please integrate *non-return valves* (see accessories).



Protect the micro annular gear pump and the electric drive against strokes and shocks.



The allowed operating parameters of the drive should not be exceeded. In particular an *incorrect polarity setting* of the supply voltage may lead to damage of the control unit.

Warning

Please insure, that the totality of the liquid supply accessories such as tubes, hoses, filters etc. are free from dust or dirt particles. Impurities such as metal, plastic or glass particles may impair or damage the pump leading to its failure.

Warning

Please operate the pump with a filter featuring 10 µm or smaller pores. It will protect the pump.

## 3 Transport and intermediate storage

### 3.1 Shipment of the pumps and protection measures

The pumps leaving the factory are secured against corrosion and shocks. The inlets and outlets of the pumps are protected with plastic plugs in order to prevent any foreign bodies from penetrating into the device.

### 3.2 Transport

In order to avoid any damage related to transport, the package must be protected against shocks. HNP Mikrosysteme guarantees, that all goods leave the factory in the best condition. Any noticed damage should be reported to the concerned forwarding agent, authorized dealer or to HNP Mikrosysteme, as manufacturer.

### 3.3 Intermediate storage

Following points concerning pump storage should be observed:

- Necessary conservation procedure (see also chapter 7.4.1)
- The protective plugs must be left screwed in
- The pump should not be stored in humid places
- For storage temperature - refer to chapter 1.3 of the present manual

## 4 Description of the micro annular gear pump

### 4.1 Operating principle of the micro annular gear pump

Micro annular gear pumps are positive displacement pumps. They contain two rotors, bearing slightly eccentrically to each other; an externally toothed internal rotor and an annular, internally toothed external rotor (see figure 5). Due to their cycloid indenting, the rotors remain interlocked at any time, forming during rotation a system of several sealed pumping chambers. As the rotors revolve around their offset axis, the pumping chambers increase on the induction (suction) side and simultaneously decrease on the delivery side of the pump (see figure 6). A homogenous flow is generated between the kidney-like inlet and outlet.

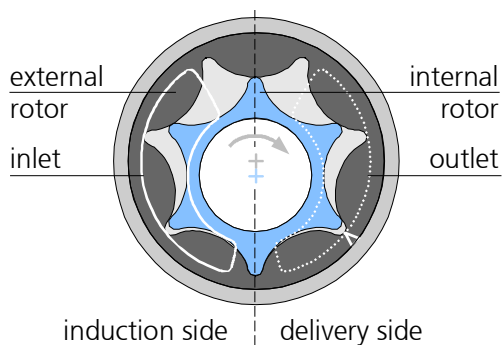

figure 5

Principle of the micro annular gear pump

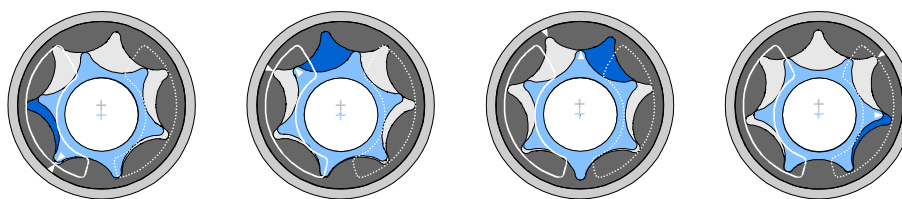

figure 6

Operating principle of the micro annular gear pump

In the case of rotary displacement pumps, the delivered amount of liquid may be easily calculated from the displacement volume  $V_g$  of the pump and the number of revolutions of the rotor  $n$ . Displacement volume stands for the volume of liquid that is moved within one revolution of the rotor. This relationship is illustrated by the following formula:

$$Q = \eta_{Vol} \cdot V_g \cdot n$$

The volumetric efficiency  $\eta_{Vol}$  shows the relationship between the actual and the theoretical flow rate. The existing differences result from internal movement of the liquid during the operation.

*Example:* According to the formula mentioned above the mzs-7255 pump featuring a displacement volume of 48  $\mu\text{l}$  delivers at 3000 rpm and with a volumetric efficiency of 100% 144 ml/min. The table 6 shows theoretical flow rate values depending on speed expressed in ml/min and ml/h.

Rotation speed [rpm]	mzs-6355		mzs-7255	
	Q [ml/min]	Q [ml/h]	Q [ml/min]	Q [ml/h]
500	12	720	24	1440
1000	24	1440	48	2880
2000	48	2880	96	5760
3000	72	4320	144	8640
4000	96	5760	192	11520
5000	120	7200	240	14400
6000	144	8640	288	17280

table 6

Theoretical flow rate of the micro annular gear pump

Pressure generated by the pump is determined by the configuration of the fluid delivery system and results from both the hydraulic pressure and the hydraulic resistance (tubing, narrow passes etc.). The *volumetric efficiency* of a pump decreases when the differential pressure rises.

The *viscosity* of the manipulated liquid has an important impact on the volumetric efficiency. The volumetric efficiency increases for higher viscosity values because the *internal leakage* values go down.

*Cavitation* is an effect which, starting from a certain limit speed value, may reduce the volumetric efficiency of a pump. In the case of highly viscous liquids this limit speed value is lower. That happens because of the liquid-specific drop of vapor pressure in the suction tube which leads to gas formation inside the pump.

The particularity of the mzs-pumps is their highly precise construction, which provides for both high operating pressures and a high dosage precision. The gap between both rotors and between the rotors and the adjacent case parts lies in the range of a few micrometers. This precision is the key factor enabling to achieve volumetric efficiency close to 100%.

## 4.2 Construction

The micro annular gear pump is composed of the pump head, the coupling unit, the drive and the angle support (see figure 7).

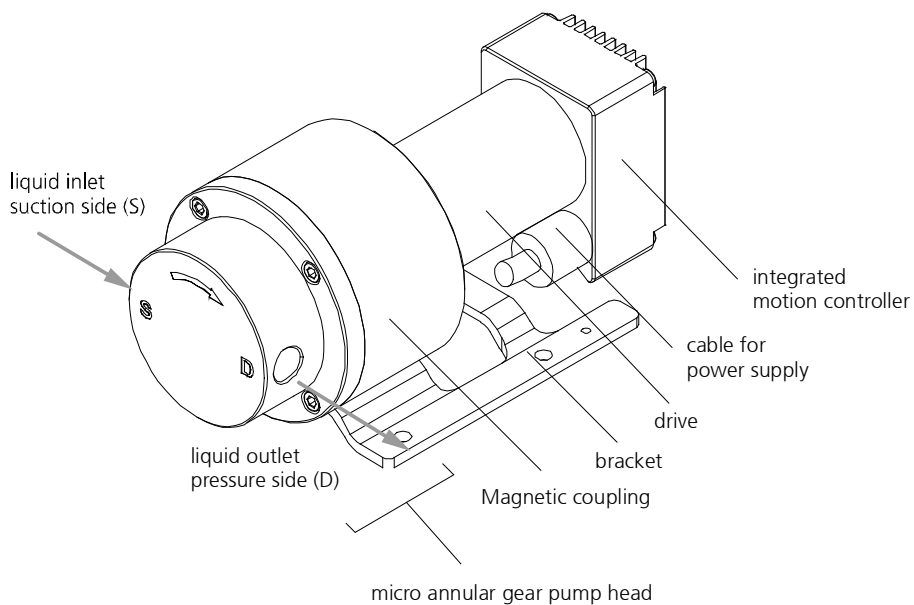

figure 7 Construction of the micro annular gear pump

### 4.3 Construction materials

The micro annual gear pumps mzs -6355 and mzs -7255 are deliverable in four different material combinations which are listed in table 7 and table 8.

Wetted parts	mzs-6355-cy / mzs-7255-cy	mzs-6355-cs / mzs-7255-cs
Rotor materials	partially stabilized ZrO <sub>2</sub>	partially stabilized ZrO <sub>2</sub>
Control plates	Al <sub>2</sub> O <sub>3</sub> ceramics	Al <sub>2</sub> O <sub>3</sub> ceramics
Pump case material	Alloy C22 (2.4602)	stainless steel 316 L
bearing material	sintered silicon carbide (SSiC), Al <sub>2</sub> O <sub>3</sub> ceramics	sintered silicon carbide (SSiC), Al <sub>2</sub> O <sub>3</sub> ceramics
shaft material	sintered silicon carbide (SSiC)	sintered silicon carbide (SSiC)
Static sealing material	FFPM (Kalrez® Spectrum™ 6375)	FFPM (Kalrez® Spectrum™ 6375)
Distance washer	PTFE	PTFE

table 7 Construction materials of the wetted parts, rotor material CVD-diamond coated tungsten carbide

Wetted parts	mzs-6355-hy / mzs-7255-hy	mzs-6355-hs / mzs-7255-hs
Rotor materials	tungsten carbide Ni-based	tungsten carbide Ni-based
Control plates	tungsten carbide Ni-based	tungsten carbide Ni-based
Pump case material	alloy C22 (2.4602)	stainless steel 316 L
bearing material	tungsten carbide Ni-based	tungsten carbide Ni-based
shaft material	tungsten carbide Ni-based	tungsten carbide Ni-based
Static sealing material	FFPM (Kalrez® Spectrum™ 6375)	FPM optional: FFPM (Kalrez® Spectrum™ 6375)
Distance washer	PTFE	PTFE

table 8 Construction materials of the wetted parts, rotor material tungsten carbide



The resistance of the construction materials to the delivered liquids should be verified by the operator for each individual application.



The material combinations and -cs and -cy can not be used for pumping water or DI water.

Pumps handling non-lubricating liquids have shorter service lives.

## 4.4 Liquid supply

<b>mzs-6355 / mzs-7255</b>	
Liquid inlet/outlet	lateral 1/8" NPT internal thread

table 9

Liquid supply

The suction side is indicated with the letter »S« the delivery side with the letter »D«. An arrow in the front of the pump indicates the operating direction of the shaft.

In order to prevent foreign bodies from penetrating into the pump, the liquid inlet and outlet are protected with plastic plugs or screws. Please remove them before you assembly the pump.

## 5 Optional modules

The spectrum of applications of the high performance micro annular gear pump series may be expanded by using different additional modules. The modules allow for special applications, which could otherwise not be accomplished with a standard pump version. The modules may be combined with each other and with almost all available pump heads and motor versions.

- *Thermal insulation module* extends the operating temperature range of the pump by protecting the motor from overheating
- *Heating module* enables to regulate the temperature of the fluid-containing parts of the pump

The configuration of a given pump version should in each case be discussed with consideration to the specific requirements of the application. *Additional* customized modules may be designed on demand.

### 5.1 Thermal insulation module

The heat insulation module enables to deliver liquids with a higher liquid temperature range table 10. It comprises thermally insulating coupling components made of plastic (PEEK) located between the pump and the drive. The drive should not be exposed to overheating. For this reason the heat transfer from the pump to the drive should be limited. An additional thermal barrier is provided by the plastic motor housing. If the surrounding temperature rises, the pump is working over a longer period or the manipulated liquid features a high temperature, convection cooling of the motor is recommended.

Material combination	Liquid temperature range
-cs	-20...+100 °C (-4 +212 °F)
-cy	-20...+100 °C (-4 +212 °F)
-hs	-20...+150 °C (-4 +302 °F)
-hy	-20...+150 °C (-4 +302 °F)

table 10

Liquid temperature with heat insulation module

## 5.2 Heating module

### 5.2.1 Electric heating module

The electric heating module enables active heating of the pump head types -cs up to 100 °C (212 °F) and -hs up to 150° C (302 °F) operating temperature. The heating module consists of a heating jacket covering the pump head and a thermal element type J. Depending on the pump size, the thermal element will be integrated on the pump head in different ways. In order to adjust the temperature of the pump head, an additional heat regulating device may be delivered.

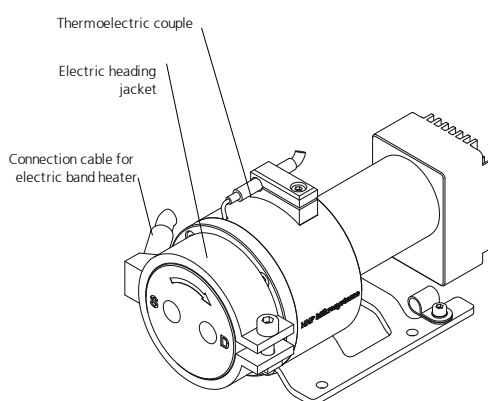

figure 8 Micro annular gear pump mzr-xx55 with the electric heating module



Before connecting the heating jacket and the thermal element to the power supply, please observe the following technical data.

Thermal element	
Type	MT-1.5
Thermal element	Type J (Fe-CuNi IEC 584) alternativ: Type L (Fe-CuNi DIN 43710)
Temperature measuring range	0 to 400 °C
Diameter of the sensing device	1.5 mm
Material	V4A (1.4541)

  

Heating jacket	mzr-6355	mzr-6355
Voltage	230 VAC	230 VAC
Power output	180 W	180 W
Diameter	50 mm	50 mm
Width	20 mm	20 mm

table 11 Technical data of the electric heating module

### 5.3 Heating device „JETmicro“

The heating device „JETmicro“ has been designed for use with the electric heating module (see chapter 5.2.1).

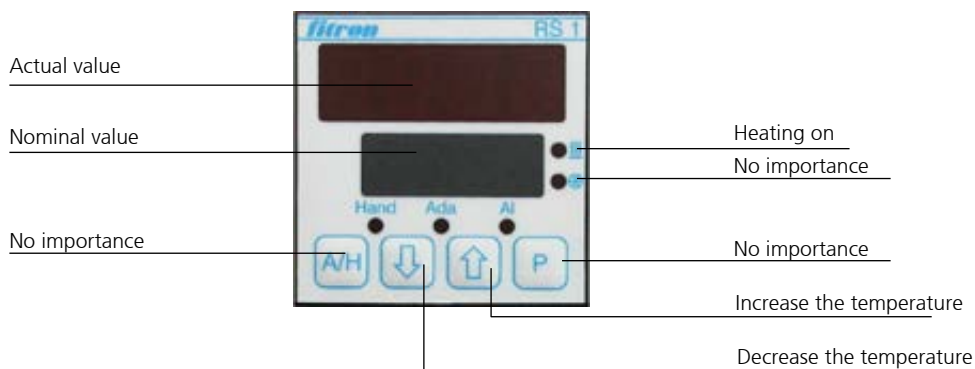

- Hand:** Blinks during temperature set in the manual input mode
- Ada:** Ada display blinks during the automatic control adjustment
- AL:** Alarm display – not configured, no importance

**Actual value display:**

OPEN = sensor failure  
cLL3 = sensor reverse polarity

With or the nominal temperature may be set.

#### Power supply

90-230 VAC, Shock-proof plug, 3 m long

#### Electrical connection

10-pole bush insert, 16 A/250 V

	Heating		Sensor	
	L	N	+	-
Zone 1	1	6	2	7

table 12 Pin configuration of the heating device

5-pole bush insert, 16 A/250 V

	Heating			Sensor	
	L	N	PE	+	-
Zone 1 and 2	3	4	PE	1	2

table 13 Pin configuration of the heating device

### 5.4 Heating device „JETmini“ (new)

The heating device „JETmini“ has been designed for use with the electric heating module (see chapter 5.2.1).

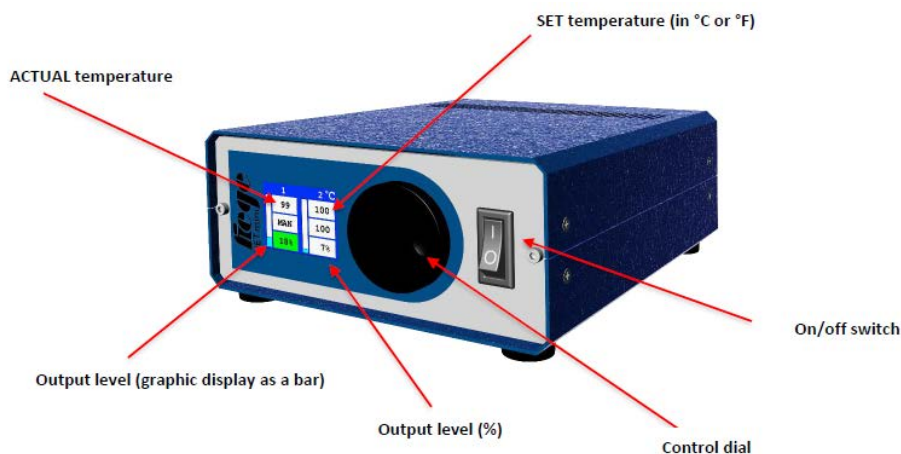

figure 9 View of heating control unit „JETmini“

#### Zonen on-/ off

All zones can be switched off by double-clicking the control dial without switching off the control device itself. The current temperatures will still be displayed. The zones are in this state immediately after switching on the control device.

1	OFF	2 °C
SB		SB
119		119
0%		0%

Control device with two zones

OFF °C
22
120
0%

Control device with one zones

#### Controlled operation

After switching on via the main switch at the front, the control device is in standby mode (zones off). The set value field displays OFF.

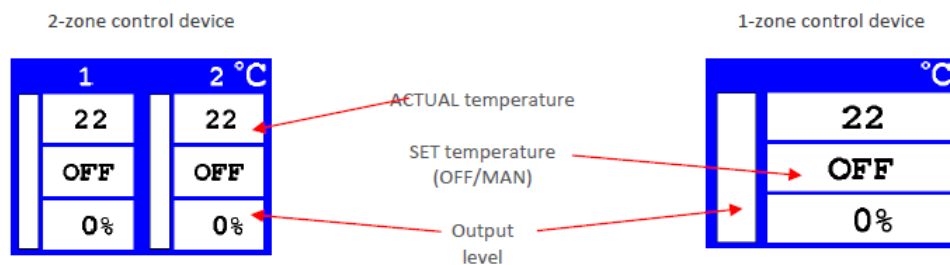

The set value is set as follows:

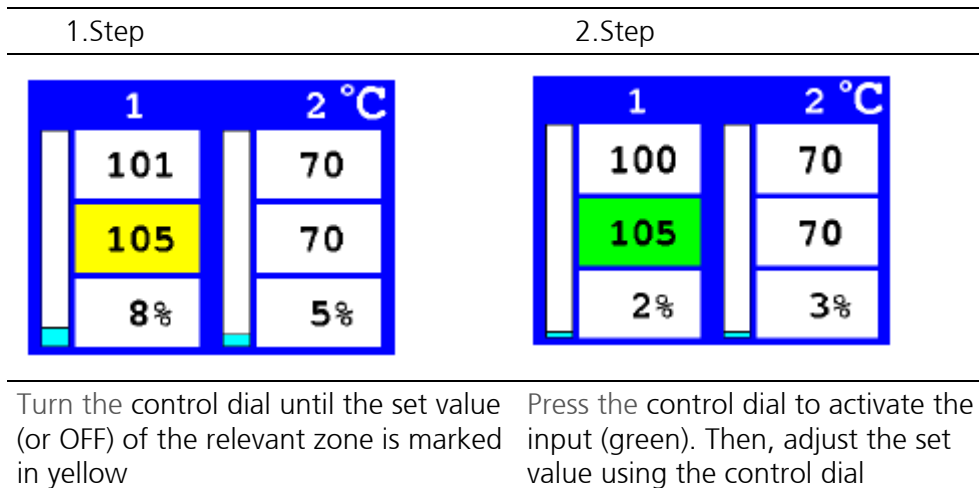

### Manual operation

The set value input of the respective zone is used to switch to manual operation. After selecting 1 degree, the switch to OFF (zone off) occurs, followed by "MAN" for manual operation. If manual operation was activated by pressing the control dial (MAN), the entry field for the output level (X%) can be selected and adjusted analogously to the temperature set value.

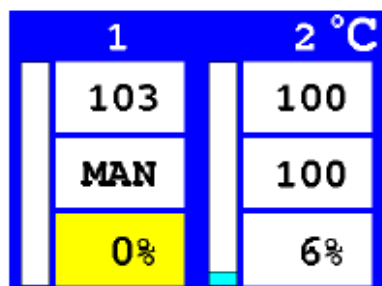

figure 10

Manual operation

### Adaptation

No adaptation is required in the delivery state. The device uses an innovative control algorithm which automatically detects the controlled system. If, in individual cases, the classic PID control system is preferred, the control algorithm may be adjusted via the advanced settings (see pt. 9). In case of the PID control algorithm, an adaptation always occurs automatically when switching on the device (mould must be connected). If temperatures > 120 degrees are present when switching on the device (again), no adaptation is carried out but the last determined control parameters are used instead. An adaptation is displayed by a flashing zone number and the signal "ADA".

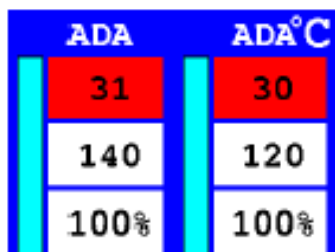

figure 11

Adaptation

### Power supply

90-230 VAC, Shock-proof plug, 2 m long

### Electrical connection

5-pole bush insert, 16 A/250 V

	Heating			Sensor	
	L	N	PE	+	-
Zone 1 and 2	3	4	PE	1	2

table 14

Pin configuration of the heating device

## 6 System integration

### 6.1 Check before the first assembly

Inspect the pumps for potential damage during the shipment (see chapter 3.2).

Please check, if the right pump type has been delivered, as according to the following points:

- Compatibility with the delivered liquid
- Viscosity range
- Pump performance (displacement volume, dosage volumes, operating pressures)
- Operating temperature range



If you notice any difference between the required and the delivered pump type, please contact HNP Mikrosysteme. Do not put the pump into operation without prior approval.

### 6.2 Mounting of micro annular gear pump

The micro annular gear pump is mounted on a bracket with M4 screws. The delivered mounting position of the micro annular gear pump is horizontal. The optimal layer to the fastening of the micro annular gear pump is horizontally with the fluid outlet (D) up so that air bubbles still can escape above. In vertical operation should drive under the pump head mounted to the pump head completely filled. However, you must pay attention that no medium can run on or into the motor.

delivery status:

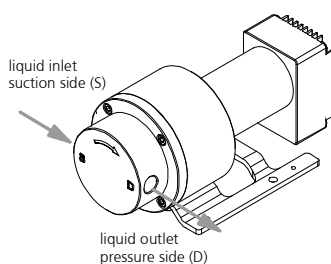

vertical mounting:

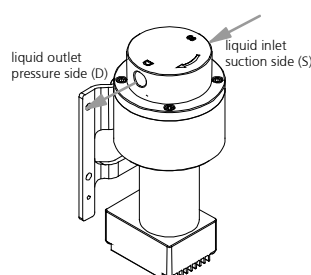

optimal mounting:

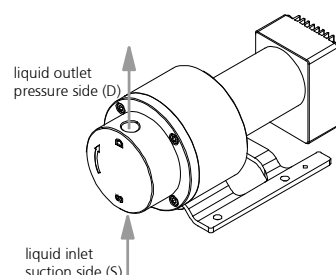

figure 12

Fitting position of the micro annular gear pump

Warning

Install the pump in such a way that in case of failure no liquid can enter the motor or controller.



Take precautions that in case of leakage no surrounding objects or environment will be damaged.



Install the micro annular gear pump only in places that fulfill the required conditions for safe pump operation.



The motor must be protected against humidity, dust or sweat.

### 6.3 General instructions for the assembly of the liquid supply network



Please always cut the tubing at a right angle with an adapted hose cutter. If metal tubes are used, an intensive cleansing procedure will be necessary. After machining the tubing has to be cleansed and flushed throughoutly. The smallest piece of swarf within the liquid delivery system may cause failure of the micro annular gear pump.



Please note that correct integration of the tubing with the pump head is a necessary condition to ensure the right direction of flow. If you wish to operate the pump in a reverse direction, please contact HNP Mikrosysteme, since it is not possible in every case.



In order to protect the interior of the pump from pollution, the pump heads are delivered with protective plugs. They should be put on when the pump is at a standstill.



For the best performance the suction tube should be as short as possible and have a large internal diameter.

Warning

In most cases the pump should be operated with a filter featuring pores that do not exceed 10 µm. The filter protects the pump from particles and dirt.

### 6.4 Assembly of the fluid connection fittings

The liquid supply openings may be lateral with an 1/8" NPT thread screw Pump heads equipped with the heating module are available with front liquid ports only.

#### Lateral screw connection 1/8" NPT

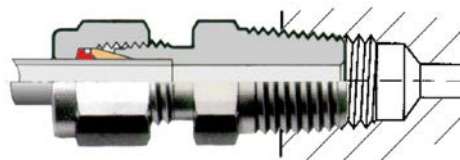

figure 13

Fluid connection fitting 1/8" NPT, stainless steel

1. The thread of the fitting should be wrapped with 2-3 layers of Teflon tape and screwed in the NPT thread (see table 15). First manually, then tightened with  $\frac{1}{2}$  to  $\frac{3}{4}$  wrench turns.



Clean the internal and external screw threads leaving no residues.



Make sure the internal and external screw threads are not dented or deformed.



Wrap the PTFE tape around the screw thread clockwise beginning with the second pitch of screw thread..



The PTFE tape should be wrapped tightly around the screw thread approx. 3 - 4 times.



Cut the PTFE tape off and wind the end of the tape tightly around the screw thread.



The PTFE tape should not stick out over screw thread because pieces can be cut off and get into the system.

table 15

#### Use of PTFE Tape

2. Cut the tube or hose to the right angle with an adapted hose cutter. Metal tubing, that produces swarf during cutting must be throughoutly cleansed and flushed. The smallest piece of swarf in the liquid delivery system may cause failure of the micro annular gear pump.
3. Screw the tube or hose (the latter always with a support tube) in the fluid inlet/outlet port of the pump first manually then tighten it with 1¼ wrench turns. During this operation use a second wrench to hold the hose against the bottom of the inlet/outlet port.
4. In order to avoid dry operation, provide for a sufficient liquid supply before each use.

## 6.5 Changing pump head

The change or rotation of the pump head with the micro annular gear pump is possible.



Bild 1 Structure in exploded view mzr-xx55



### Caution with magnetic forces! Caution: risk of jamming fingers!

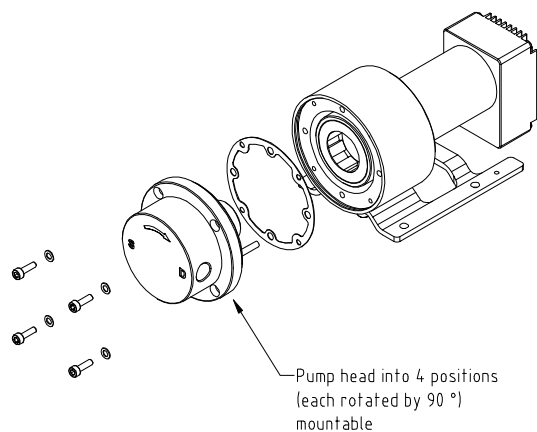

When removing the pump head, pay attention to the magnetic forces of the magnetic coupling. It can come to a renewed withdrawal into the magnetic coupling, which can lead to jamming of the fingers.

When inserting the pump head, pay attention to the magnetic forces of the magnetic coupling. It can come to a draw, which can lead to jamming of the fingers.



The open drive unit should preferably be covered to protect it from magnetic objects (screws, washers, tools).



Before inserting the pump head, check whether the magnetic coupling is free of foreign objects. These may need to be removed.

## 6.5.1 Steps

### 6.5.1.1 Disassembly

1. A clean workplace or a clean work surface is indispensable!
2. Loosen and remove screws.
3. Hold the pump head from the case part fitting and carefully pull it out of the clutch bell. Do not twist (centering pins available).  
 ⚠ **Caution with magnetic forces!** Risk of jamming!
4. If the pump head can't be loosened, use a large 4 mm wide flat screwdriver to help lever, by gently placing it in the notch situated on the bottom of the pump.

### 6.5.1.2 Assembly

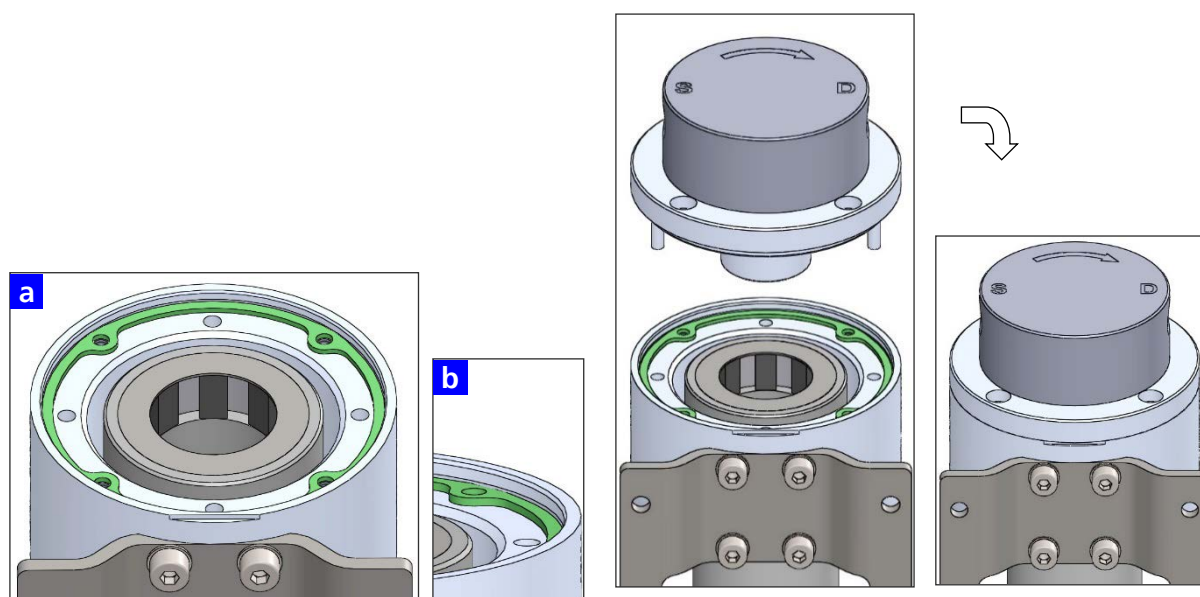



figure 2

Assembly view m zr-xx55

1. Insert sealing gasket: Check the sealing gasket for damage and replace, if necessary. Place the sealing gasket in the cavity (Fig. 2 **a**) of the clutch bell - the boreholes of the sealing gasket must match the threaded holes in the clutch bell.
2. Press the sealing gasket into the undercut **b** of the recess until it rests flat.  
 ⚠ **Attention!** Do not use sharp objects or tools to avoid damaging the coating on the sealing gasket!

3. For alignment: the pump head must be inserted in such a way that, when looking at the pump head, the suction side is on the left and the pressure side to the right. (Normal orientation)  
 Note! Depending on the requirement, it is also possible to mount the pump head by 90 °, 180 ° or 270 ° to this position!
4. For mounting: Hold the pump head from the case part fitting and carefully place it on the coupling unit - make sure that the centering pins engage in the corresponding holes. Do not hit the outer magnet system with the pump head.  
 Caution with magnetic forces! Risk of jamming!
5. If necessary, press the pump head gently against the coupling unit until it rests evenly.
6. Insert screws: Depending on the material of the coupling unit insert the following screws and washers  $d_i = 3.2$  in the four holes of the pump head.

PEEK coupling unit: M3x12

Stainless steel coupling unit: M3x10

7. Tighten the pump head: Depending on the material of the coupling unit, tighten the screws - crosswise - with a torque wrench and the following torque.

PEEK coupling unit: 0.6 Nm

Stainless steel coupling unit: 0.8 Nm

## 6.6 Filter selection and use

In majority of cases it is recommended to integrate a filter on the suction side of the micro annular gear pump to ensure its secure operation. The recommended filter pores or mesh size should not exceed 10 µm. The penetration of particles or swarf that could cause a blockage or damage to the pump can only be avoided by using an adapted filter.

HNP Mikrosysteme offers a choice of standard filters covering a broad spectrum of applications. You may count on our assistance for the selection of the most suitable one.

In order to select the best adapted filter, such operating parameters as flow rate, viscosity and degree of pollution of the liquid will be needed. An increase in at least one of the mentioned terms will require the use of a bigger filtering element or the pressurization of the delivered liquid. In case no suitable filter for high viscosity liquid can be found, it is possible to use a filter with slightly larger pore size. Prior discussion with HNP Mikrosysteme is here recommended. A filter with larger pores is still better than no filter at all. Alternatively an already filtered liquid may be used.

### Warning

Because filters have a large internal volume, it is recommended to fill in the filter and the suction tube with already filtered liquid in order to avoid dry operation of the pump during the startup.

### Warning

Please control regularly the filtering elements for pollution. Cleanse regularly the filter or replace it with a new one. A polluted filter may considerably decrease the volumetric efficiency of a pump. Furthermore, because of the cavitation effects dosage imprecision and even pump damage may occur.

### Warning

A too small filter (too little filtering surface) may considerably decrease the volumetric efficiency of the micro annular gear pump. What is more, because of the cavitation effects dosage imprecision and even pump damage may occur.

## 6.7 Connection of the micro annular gear pump to the power supply

In order to operate the pump a supplementary source of 24 VDC will be required. The ampacity of the voltage source should amount to 5 A for the micro annular pumps mzr-6355 and mzr-7255.

The micro annular gear pump is connected via the Terminal Box S-G05. This enables an easy startup of the pump due to:

- the possibility to connect the voltage supply with the delivered plug connector J1
- alternative voltage supply via a DIN connector conform with DIN 45323
- separable pump connection "mzr-pump"
- speed set via potentiometer
- analog voltage input 0-10 V and 0 (4)-20 mA for speed control
- change of speed setting mode with a DIP-switch
- 9-pole connection plug for the RS-232 interface
- error output programmable also as trigger input or frequency output
- digital input with a screw connection
- possibility of installation on a 35 mm top hat rail

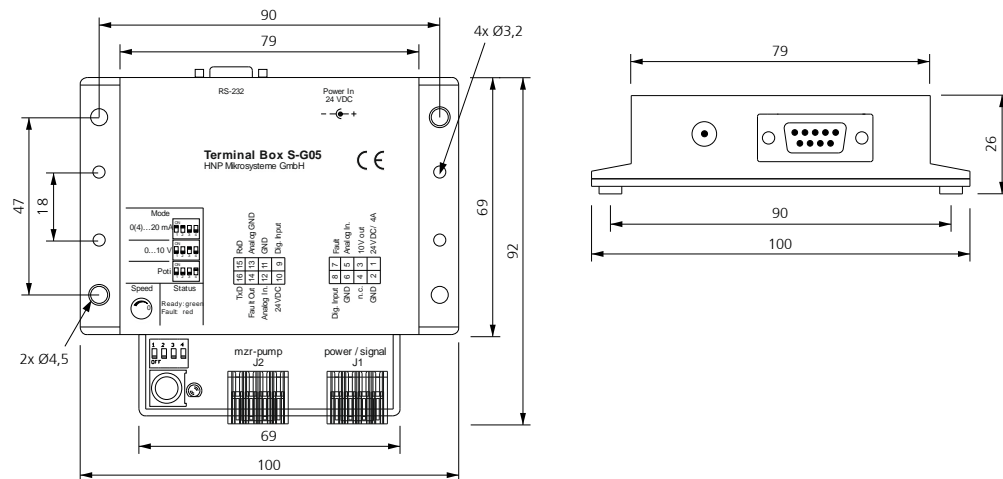

figure 14

Measurements of the Terminal Box S-G05

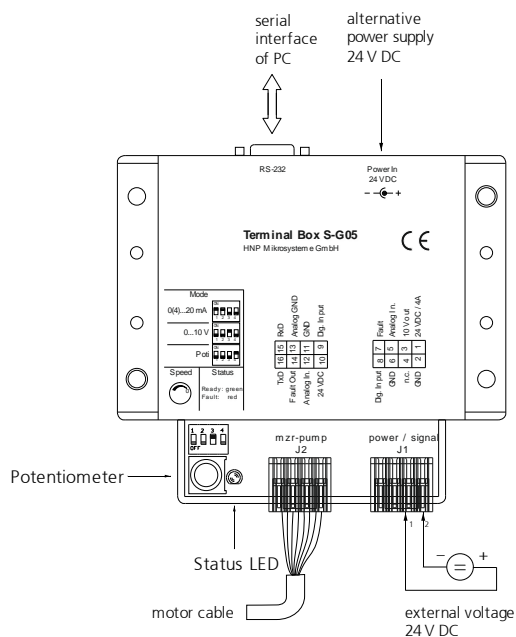

figure 15 Connection of the micro annular gear pump to the power supply

Connector J1 Pin	Function	Labeling Terminal Box
1	Voltage supply	24 VDC / 4 A
2	Ground	GND
3	10 V output voltage	10 V Out
4	not used	n.c.
5	Analog input	Analog In
6	Ground	GND
7	Fault output	Fault
8	Digital Input	Dig. Input

table 16 Connector J1 "power / signal" pin assignment of Terminal Box S-G05

Connector J2 Pin	Function	Wire	Labeling Terminal Box
9	Digital Input	red	Dig. Input
10	Voltage supply	pink	24VDC
11	Ground	blue	GND
12	Analog input	brown	Analog In
13	Ground analog input	grey	Analog GND
14	Fault output	white	Fault Out
15	RS-232 interface signal reception	yellow	RxD
16	RS-232 interface signal transmission	green	TxD

table 17 Connector J2 "mzs-pump" pin assignment configuration between the motor and terminal box S-G05



#### Installation of the cable wires

- tool: screwdriver blade 2.5 x 0.4 mm
- open the spring clamp with the screwdriver through the side slot
- cable in cable opening place (cable can be used with or without ferrule)
- remove the screwdriver

figure 16

Installation of cable wires in the connectors

LED Status	Definition
green	Power supply to the controller is active, no error
red	Motor error (current limitation or pump blocked)

table 18

LED for status indication

The operating speed of the micro annular gear pump may be set with:

- the potentiometer of the Terminal Box S-G05
- an external voltage signal 0-10 V
- an external, analog current signal 0 (4)-20 mA
- an external potentiometer and
- the RS-232 interface

Individual start up procedures are described in the following points.

### 6.7.1 Startup with potentiometer

1. Connect the drive with the eight colored wires to the terminal box S-G05. The colors of the corresponding wire connections are described in the table 17.
2. Bring the potentiometer knob to null position by turning it clockwise to the limit stop.
3. Put the DIP-switch to the »Poti« position.
4. Connect the 24 VDC voltage supply to the terminal or to the DIN connector.



Make sure that the polarity of the supplied direct current is correct, otherwise electronics will be damaged.

5. Provide for a steady liquid supply to the pump in order to avoid dry operation.
6. The pump may now be put into operation by turning on the potentiometer knob.

*Remarks:*

- You may adjust speed of the micro annular gear pump without the need to connect it to the serial interface.
- In case error occurs for example due to motor overload - the green status LED on the Terminal Box S-G05 will turn red.

**6.7.2 Startup with external 0-10 V signal**

1. Connect the drive with the eight colored wires to the terminal box S-G05. The colors of the corresponding wire connections are described in the table 17.
2. Bring the potentiometer knob to the null position by turning it clockwise to the limit stop.
3. Put the DIP-switch to »0...10 V« position.
4. Connect an external 0-10 V voltage supply to the terminal clamps »AnalogIn« and »GND« to the S-G05. (see figure 17)

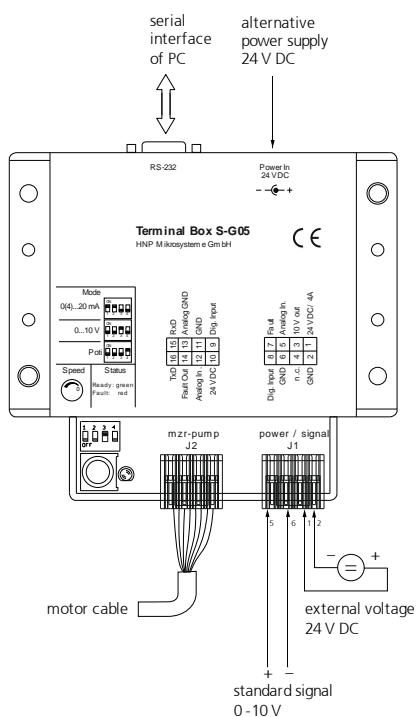

figure 17

Startup with an external 0-10 V voltage signal

5. Provide for a steady liquid supply to the pump in order to avoid dry operation of the device.
6. Connect the 24 VDC voltage supply to the terminal or to the DIN connector.



Make sure that the polarity of the supplied direct current is correct, otherwise electronics will be damaged.



The input circuit at the analog input is layed out as a differential amplifier. If the analog input is "open" there is already a voltage of 2 V. That means in this case that the motor would be turning at a speed of about 2000 rpm. In order to set 0 rpm the input must be connected over a low ohm resistor to the analog ground (AGND) or connected to the AGND-voltage level.

7. The micro annular gear pump may now be put into operation by increasing the external voltage signal. A voltage signal of 0 V corresponds to 0 rpm and 10 V to the maximal programmed speed.

*Remarks:*

- You may adjust speed of the micro annular gear pump without the need to connect it to the serial interface.
- In case error occurs for example due to the motor overload - the green status LED on the terminal Box S-G05 will turn red.

### 6.7.3 Startup with an external 0(4)-20 mA current signal

1. Connect the drive with the eight colored wires to the terminal box S-G05. The colors of the corresponding wire connections are described in the table 17.
2. Bring the potentiometer knob to the zero position by turning it clockwise to the limit stop.
3. Put the DIP-switch to »0(4)...20 mA« position.
4. Connect the external current source to the screw clamps »AnalogIn« and »GND« to the S-G05. (see figure 18).

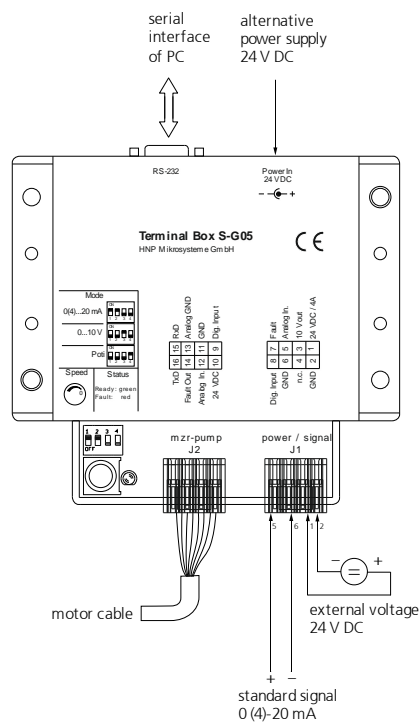

figure 18 Operation via an external 0 (4)-20 mA voltage

5. Provide for a sufficient liquid supply to the pump in order to avoid dry operation of the device.
6. Connect the 24 VDC voltage supply to the screw clamp terminal or to the DIN connector.



Make sure that the polarity of the supplied direct current is correct, otherwise electronics may be damaged.

7. The micro annular gear pump may now be put into operation by increasing the external current signal. 0 mA corresponds to 0 rpm and 20 mA to the maximal programmed speed.

#### Remarks:

- For operation with the signal 4...20 mA an offset of about 2.1 V should be set by entering the command MAV2170. In order to set the nominal values the micro annular gear pump must be put into operation via the RS-232 interface and start with the » Motion Manager « software. Save the command in the EEPROM with the command EEPSAV (see chapter 9.1).
- Speed of the micro annular gear pump may be set by sending an external voltage signal without the need to connect the pump to the serial interface.
- In case error occurs for example due to a motor overload - the green status LED on the Terminal Box S-G05 will extinguish and a red one will light up.

### 6.7.4 Startup with external potentiometer

1. Connect the drive with the eight colored wires to the terminal box S-G05. The colors of the corresponding wire connections are described in the table 17.
2. Bring the internal potentiometer knob to the null position by turning it clockwise to the limit stop.
3. Put the DIP-switch to »0...10 V« position.
4. Connect an external 0-10 V voltage supply to the terminal clamps »AnalogIn«, »10 V« and »GND« to the S-G05.(see figure 17)

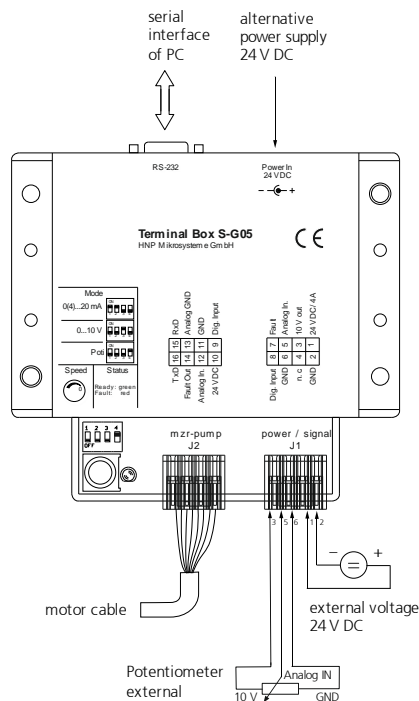

figure 19

Startup with an external potentiometer

5. Provide for a steady liquid supply to the pump in order to avoid dry operation of the device.
6. Connect the 24 VDC voltage supply to the terminal or to the DIN connector.



Make sure that the polarity of the supplied direct current is correct, otherwise electronics will be damaged.



The input circuit at the analog input is laid out as a differential amplifier. If the analog input is "open" there is already a voltage of 2 V. That means in this case that the motor would be turning at a speed of about 2000 rpm. In order to set 0 rpm the input must be connected over a low ohm resistor to the analog ground (AGND) or connected to the AGND-voltage level.

7. The micro annular gear pump may now be put into operation by increasing the external voltage signal. A voltage signal of 0 V corresponds to 0 rpm and 10 V to the maximal programmed speed.

*Remarks:*

- You may adjust speed of the micro annular gear pump without the need to connect it to the serial interface.
- In case error occurs for example due to the motor overload - the green status LED on the terminal Box S-G05 will turn red.

### 6.7.5 Startup with the RS-232 interface

8. Connect the drive with the eight colored wires to the S-G05. The colors of the corresponding wire connections are in the table 17.
9. In order to prevent uncontrolled startup of the pump, bring the potentiometer knob to the null position by turning it clockwise to the limit stop.
10. Put the DIP-switch to »Poti« position.
11. Connect the RS-232 interface of the Terminal Box S-G05 with a free serial interface of a PC. Use for that the delivered 9-pole null-modem cable.
12. Now install the delivered software as described in the chapter 8 or Chapter 9.
13. Connect the 24 VDC voltage supply to the terminal or to the DIN connector.
14. Provide for a steady liquid supply to the pump in order to avoid dry operation of the device.
15. The micro annular gear pump may now be put into operation with the available software (operating mode RS-232 see chapter 9.1).

*Remarks:*

- In case error occurs for example due to the motor overload - the green error status LED on the Terminal Box S-G05 will turn red.

### 6.7.6 Startup of the pump units with network mode (NET1 Command)

All standard units are delivered with node number 0. In order to prepare the units for network operation, they must first be individually connected to the PC and set to the desired node address using the FAULHABER Motion Manager.

A serial network can be constructed using the so-called daisy-chain technique, in which the transmit cable of the Master (PC, PLC) is connected to the receive cable of the first node, from where it is looped through to the receive cable of the second node, and so on. The same procedure is followed with the receive cable of the Master, which is looped through to all transmit cables of the drive node. The current generation of Motion Controllers do not require a multiplexer board for serial network operation. The multiplex mode is activated with a command NET1.

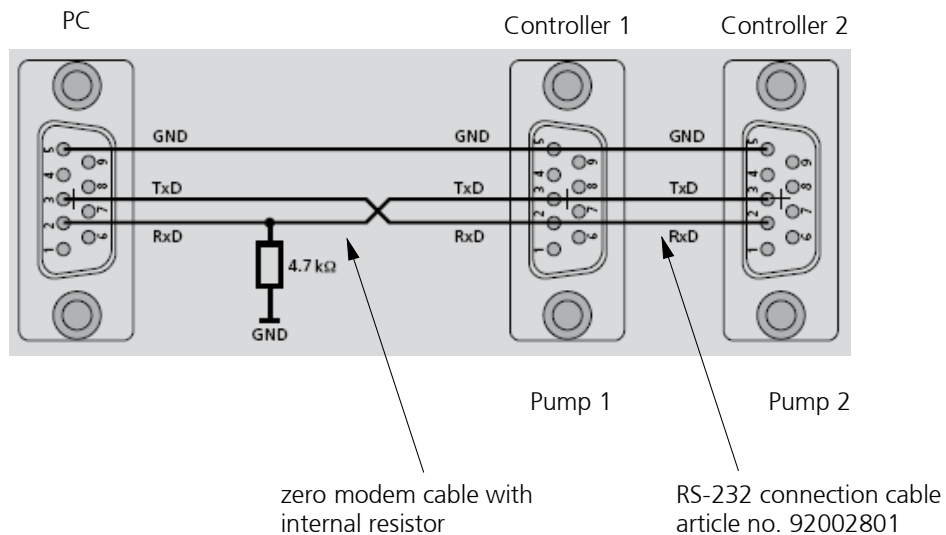

figure 20

Connection between PC, Controller Pump 1 and Controller Pump 2

1. Connect the RS-232 port of the controller Pump 2 with the RS-232 of the controller Pump 1. For this purpose use the delivered 9-pole RS-232 connection cable.
2. Connect the In Port of the RS-232 connection cable with a free serial interface of a PC. For this purpose use the delivered 9-pole null-modem cable with internal resistor.
3. Put the potentiometer of the control units to zero position by turning it clockwise to the limit stop.
4. Connect the voltage supply 24 VDC. This can be done with the integrated DIN connector or, alternatively the 2-pole screw clamp (24 V = »+«; GND = »-«). Pay attention to the correct polarity.
5. You may now install the delivered software as described in the chapter 8.



While connecting the DC voltage pay attention to the correct polarity, otherwise electronics may be damaged.

*Remarks:*

- Controller which the manufacturer specifically shipped for the network modus were with the command NET1, SOR0, ANSW0 and DIPROG programmed.
- In order to address the individual drives in the network, the node number must be specified before each ASCII command to be sent (e.g. 2V500). Commands without a node number are adopted by all drive nodes in the network.
- No unaddressed query commands may be sent in network mode, as otherwise all units will answer simultaneously and the message frames will mix, resulting in communication errors. It must also be ensured that no asynchronous responses are sent by several units simultaneously, and that the command acknowledgement is switched off when using unaddressed transmit commands. Use the ANSW0 command to set the response behaviour.

## 6.8 Connection of the micro annular gear pump with terminal box S-G05 with screw clamp terminal

In order to operate the pump a supplementary source of 24 VDC will be required. The ampacity of the voltage source should amount to around 3 A for the micro annular pumps mZR-2505, mZR-2905 and mZR-4605 and 5 A for the mZR-7205.

The micro annular gear pump is connected via the Terminal Box S-G05. This enables an easy startup of the pump due to:

- the possibility to connect the voltage supply with the delivered screw clamp terminal
- an alternative voltage supply via a DIN connector conform with DIN 45323
- speed set via potentiometer
- analog voltage input 0-10 V and 0 (4)-20 mA for speed control
- change of speed setting mode with a DIP-switch
- 9-pole connection plug for the RS-232 interface
- error output programmable also as trigger input or frequency output
- digital input with a screw connection
- possibility of installation on a 35 mm top hat rail

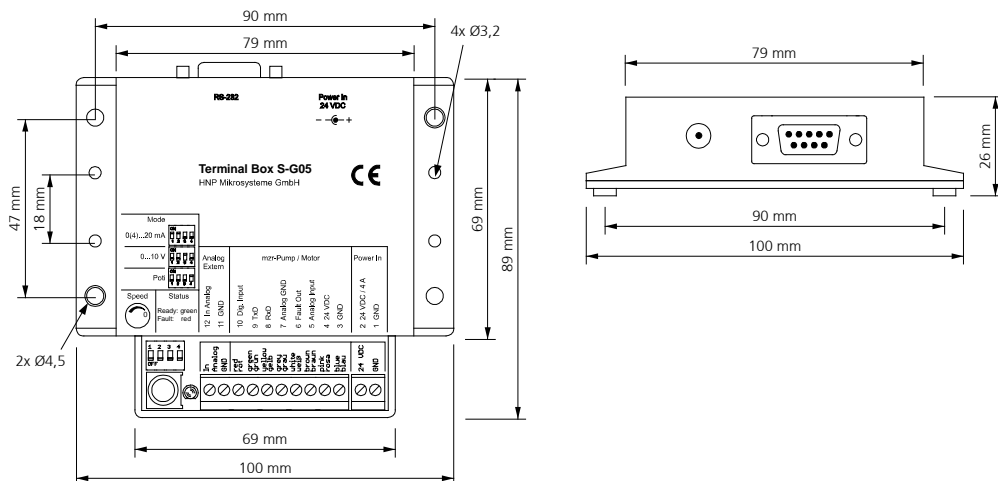

figure 21

Measurements of the Terminal Box S-G05

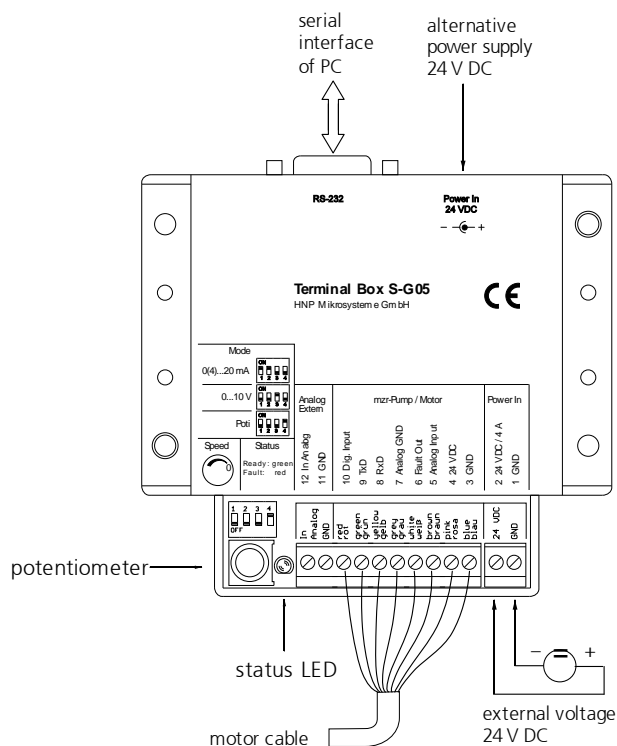

figure 22

Connection of the micro annular gear pump to the power supply

Wire	Function	Terminal Box
blue	Ground	GND
pink	Voltage supply	24VDC
brown	Analog input	Analog Input
white	Error output	Error Out
gray	Ground analog input	Analog GND
yellow	RS-232 interface signal reception	RxD
green	RS-232 interface signal transmission	TxD
red	Digital input	Dig.Input

table 19

Wire configuration between the drive and the Terminal Box S-G05

The speed setting in operation of the micro annular gear pump is to implement the functions from chapter 6.7. The connection of an external potentiometer can't be realized.

## 7 Startup/shutdown of a mzr-pump

### 7.1 Preparing for operation

After the liquid supply system had been completed, please check once again the operating conditions of the micro annular gear pump as according to the following points:

- Are the inlet and outlet tubes correctly connected?
- Is the entire liquid supply system clean - that means free of particles, foreign bodies, pollution or swarf?
- Has a filter been installed on the suction side?
- Has a sufficient amount of the right liquid been supplied?
- The pump does not run the risk of a dry operation?
- The entire liquid supply system has been checked for leakage?
- Is it possible to stop the pump by an emergency switch if an unexpected malfunction occurs at the startup?

### 7.2 Startup of the micro annular gear pump

Switch on the voltage supply. The micro annular gear pump can now be put into operation by turning on the potentiometer knob or by sending a nominal external voltage signal.

Start the filling in of the pump at low or middle speed (1000 - 3000 rpm).

#### Warning

Avoid dry operation of the pump. The pump should be filled in before it is put to operation.

### 7.3 Flushing procedure after use

After each service the micro annular gear pump should be carefully flushed with a non-corrosive, filtered and particle-free flushing liquid (see table 20 and table 21). During flushing procedure the pump should operate at a speed of about 3000 rpm and if possible against a low pressure (that can be obtained by using a restrictor, a capillary or similar). The flushing liquid must be compatible with the delivered liquid and suitable for solving the remaining liquid rests. Depending on the application for example water, or isopropanol may be used. If you have doubts whether a particular liquid is suitable for this function or not, please ask the manufacturer of the liquid or HNP Mikrosysteme.

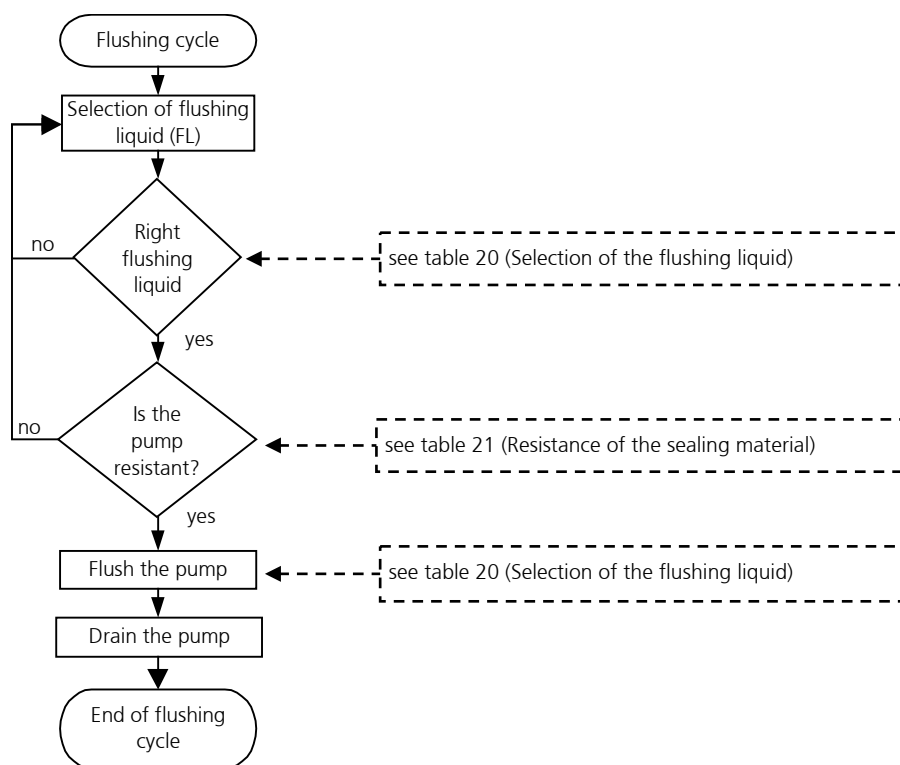

figure 23

Diagram of the flushing procedure

Warning

Liquids that remain in the pump may crystallize, coagulate or lead to corrosion and as a consequence impair the work of the micro annular gear pump.

Warning

Please make sure that the pump components and particularly O-rings and sealing are resistant to the employed flushing liquid. (see table 21).

Warning

The flushing liquid (solvent) and the recommended duration of the flushing procedure depend on the delivered liquid (see table 21). The indicated flushing liquids are simple recommendations and should therefore be checked by the user as to their compatibility and suitability.



Regulations concerning use of substances dangerous to health should be followed!

	Nature of the delivered liquid	Flushing time [min]	Suitable flushing liquid
1	Oils, fats, plastifiers	15-20	isopropanol, ethanol, acetone, benzine/petroleum ether
2	Solvents (polar + nonpolar)	5-10	isopropanol, ethanol
3	Other organic liquids	10-15	isopropanol, ethanol
4	Refrigerating and cooling agents	15-20	isopropanol, ethanol
5	Neutral water/y solutions	20-25	isopropanol, ethanol
6	Basic solutions	25-30	DI-water (deionized water)
7	Organic acids	30-40	isopropanol, ethanol
8	Weak mineral acids	25-30	DI- water
9	Strong mineral acids	35-45	DI- water
10	Strong oxidizing liquids	35-45	DI- water
11	Paints, varnishes, adhesives	50-60	not specified - for further information please contact HNP Mikrosysteme.

table 20 Selection of the flushing liquid (solvent) and the duration of the flushing procedure depending on the delivered liquid.

Warning



Please make sure that the pump components and particularly O-rings and sealing are resistant to the employed flushing liquid (see table 21).

The material combinations and -cs and -cy can not be flushed with water or DI-water.

Flushing liquid	FPM	O-ring material	
		EPDM	FFPM
acetone	3	0	0
benzene	1	3	0
benzyl alcohol	0	2	0
butanol	1	0	0
dimethyl sulfoxide (DMSO)	3	0	0
ethanol	0	0	0
isopropanol	0	0	0
methanol	2	0	0
methylethylketone (MEK)	3	1	0
styrene	1	3	1
toluene	2	3	0
water	0	0	0
xylene	2	3	0
benzine/petroleum ether	0	3	0
oil / fine mechanics oil	0	3	0

Legend: 0 ... good suitability 1 ... suitability 2 ... conditional suitability 3 ... labile - ... not specified

table 21 Resistance of the sealing materials depending on the flushing liquid (solvent)

## 7.4 Shutdown of the micro annular gear pump

In order to shut down a mzs-pump the following steps should be followed:

- Flush the pump with a filtered and particle-free flushing liquid (solvent) as described in the chapter 7.3.
- After the flushing procedure decrease speed of the pump to 0 rpm
- Fill the pump with a suitable conservation liquid (see chapter 7.4.1)
- Remove the pump from the system (see chapter 7.4.2)

By proceeding as shown in the diagram (see figure 25) you may prepare the pump for a longer standstill.

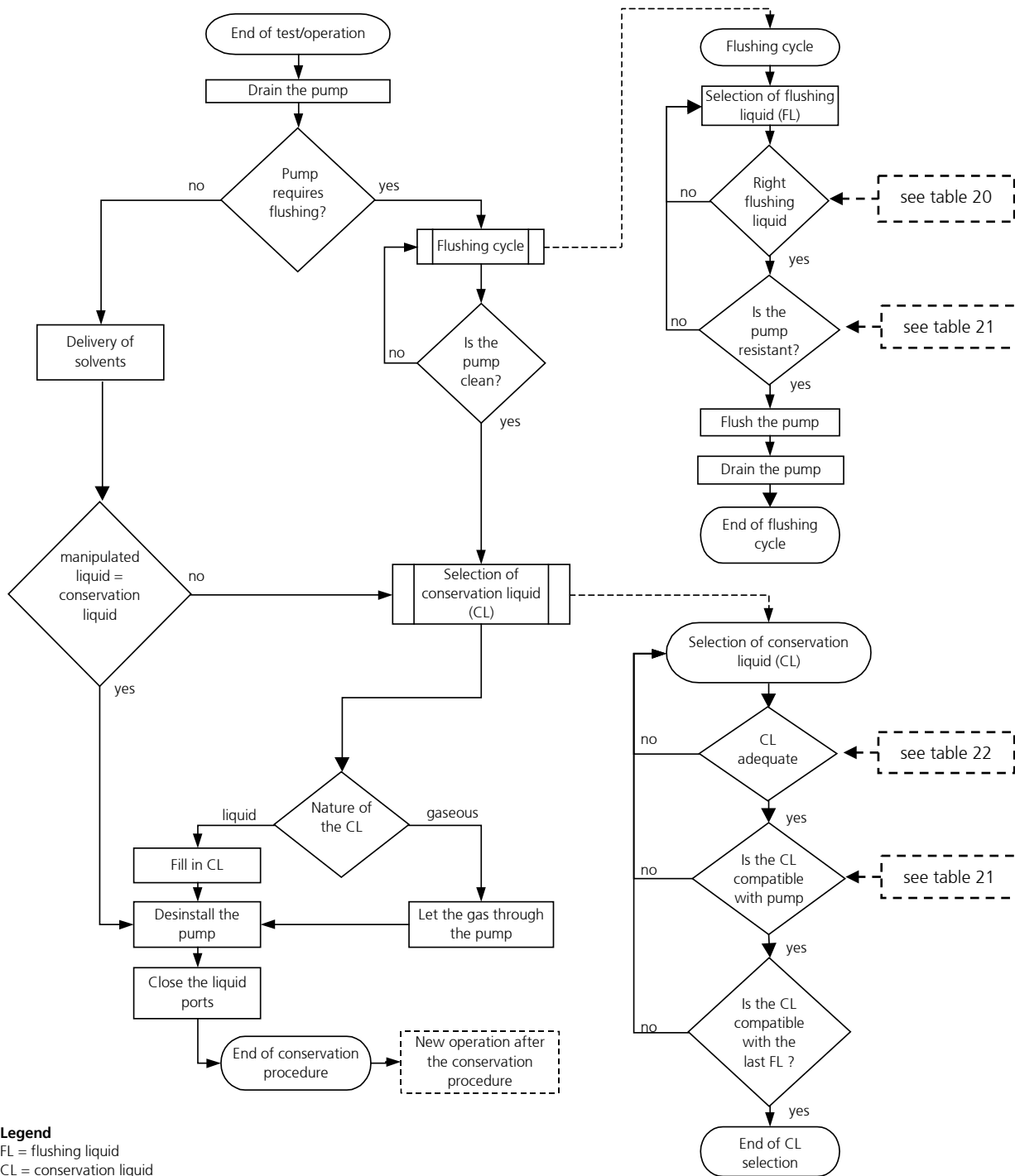

figure 24 Diagram of the shutdown procedure

### 7.4.1 Conservation

If the micro annular gear pump operates at irregular intervals or for other reasons should be put out of operation for a longer period, it should, after service and flushing procedure (see chapter 7.3), be filled in with a suitable conservation liquid.

The conservation liquid may be selected from the table 22 depending on the duration of the standstill and the resistance of the pump to the manipulated liquid. The indicated conservation liquids are simple recommendations and should therefore be checked by the user as to their compatibility and suitability. The figure 25 presents a diagram of conservation agent selection.

*Remark:* This diagram is repeated as a part of the figure 24 (shutdown procedure of the micro annular gear pump).

After the cleansing procedure the pump should be filled with a suitable conservation agent. You will find a choice of possible conservation agents in the table 23

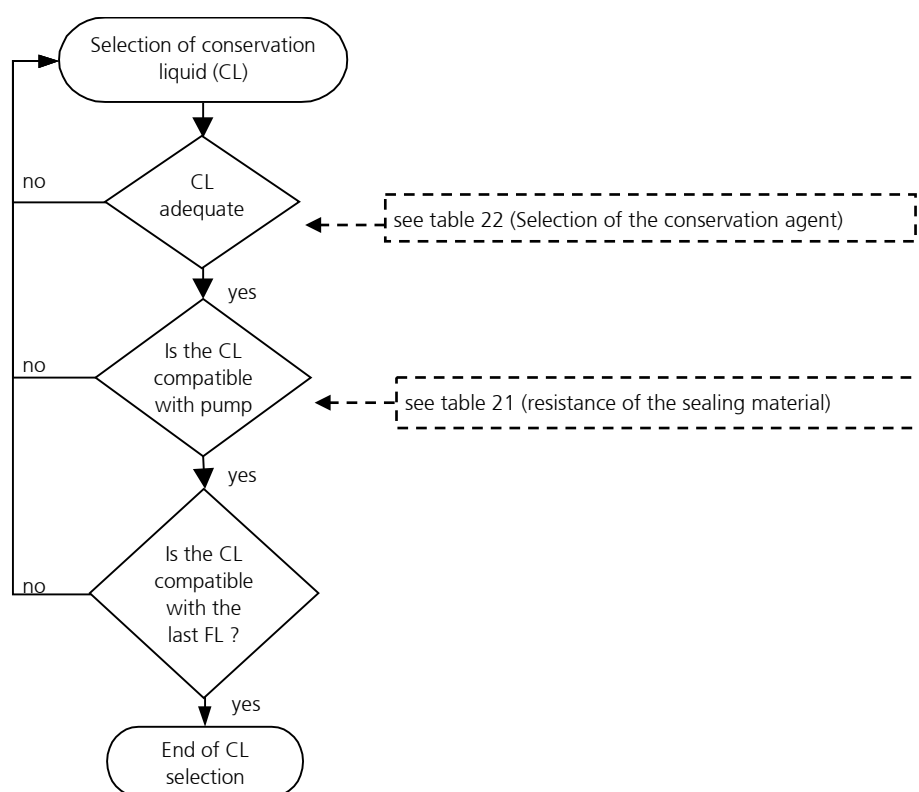

figure 25

Diagram - selection of conservation liquid (CL)

Liquids	Solubility in water	Compatibility with the delivered liquid	Duration of storage	Breakaway torque	Toxicology	Viscosity	Description
isopropanol	+	+	o	o	o	+	solvent for organic compounds, cosmetics, essential oils waxes, and esters, antifreezers, antiseptic agents
acetone	+	+	o	o	o	+	solvent for a number of organic compounds, unlimited solubility in water, dissolves natural and synthetic resins, fats, oils and commonly used plastifiers
ethanol	+	+	o	o	o	+	solvent for organic compounds, fats, oils and resins
DI-water	+	+	-	-	+	+	solvent for many organic and mineral liquids
fine mechanics oil	-	-	+	+	+	+	cleansing and protective action (dissolves fats, tar, rubber or adhesive substances, protects against corrosion).
hydraulic oil	-	-	+	+	+	-	lubricating and preserving properties ( <i>Warning</i> : may resinate or deteriorate with time)
nitrogen	-	+	+	+	o	+	is not a solvent, may leave deposits after drying out
air / compressed air		+	+	+	+	+	is not a solvent, may leave deposits after drying out

Legend: + ... good/suitable o ... satisfactory; - ... bad/inadequate

table 22 Selection of the conservation agent

In order to prevent dust particles and foreign bodies from penetrating into the pump or the conservation agent from leaking out, please secure the liquid input and output openings with the delivered protective plugs or screws.

#### Warning

Water or DI-water should not be used as conservative liquids. They germinate already after a few days and build a biofilm which can later block the pump.

## 7.4.2 Dismantling of the system

- Put the drive out of operation by turning down speed to 0 rpm and by switching off the voltage supply. Make sure that the procedure described in the chapter 7.3 has been completed.
- Now that the pump has been stopped you may remove it from the system.
- Protect the inlet and outlet openings of the pump with adapted protective plugs or screws.

## 7.5 Trouble shooting

If the pump stops operating abruptly or has difficulties with starting operation, please undertake the following steps:

Try to liberate the micro annular gear pump:

- by turning the potentiometer knob back and forth or by connecting an analog voltage
- via the control software
- by pressing with a syringe a suitable flushing liquid (see table 20 and table 21) through the micro annular gear pump
- by changing the operating direction of the pump.

If these measures turn out to be ineffective, please contact the service staff of HNP Mikrosysteme (see chapter 16) and send the pump back to the manufacturer for inspection.

### Warning

*You should under no condition try to disassemble the pump by yourself. This may cause damage to the pump components and consequently annul your warranty claims.*

## 7.6 Return of the micro annular gear pump to the manufacturer

For the return of a micro annular gear pump and components that have already been employed, please follow the instructions:

- drain any remaining rests of the delivered liquid from the pump
- flush the pump with an adapted solvent
- remove the filter elements from integrated or loosely delivered filters
- protect all openings against dust with the delivered protective plugs or screws
- return the pump in its original packing

The service personnel which carries out the repair should be informed about the condition of the already used micro annular gear pump. This is done by means of the "Declaration of media in contact with the micro annular gear pump and its components" (see chapter 19). This form may also be downloaded from the web site <https://www.hnp-mikrosysteme.de/service/download-center.html>.



The "Declaration of liquids in contact with the micro annular gear pump and its components" must imperatively be filled in. The nature of liquid which entered into contact with the micro annular gear pump and its components must be specified.

In case of non-compliance, the sender will be liable for any resulting injure to persons or any object damage.

## 8 Software »mzr-pump controller«

Install the delivered software »mzr-pump controller« from both diskettes by starting the program »Setup« on CD. The delivered software is compatible with Windows 98®, Windows NT, Windows 2000®, Windows XP® and Windows Vista™.

After a successful installation the program »mzr-pump controller« can be found in the start menu under »Programs - HNP Mikrosysteme«. After the program has been initiated, data such as the pump type »mzr-6355« or »mzr-7255«.

The program enables to coordinate metering or continuous delivery tasks. The operating parameters of the micro annular gear pump are set via included user interface.

The »Dosage« operating mode (see figure 26) enables to set constant volumes in units such as ml, mg or rpm as well as pauses for a fixed number of sequences or for continuous operation. Each metering procedure will be configured according to the speed profile which is set for such values as »Max. velocity« and the »Acceleration«. The allowable speed values extend from 1 to 6000 rpm and the acceleration values from 1 to 2000 rotation/s<sup>2</sup>.

The metering procedure can be initiated with the »Start« button or by pressing the enter key. The task may be stopped either with the »Stop« button or by pressing once again the enter key.

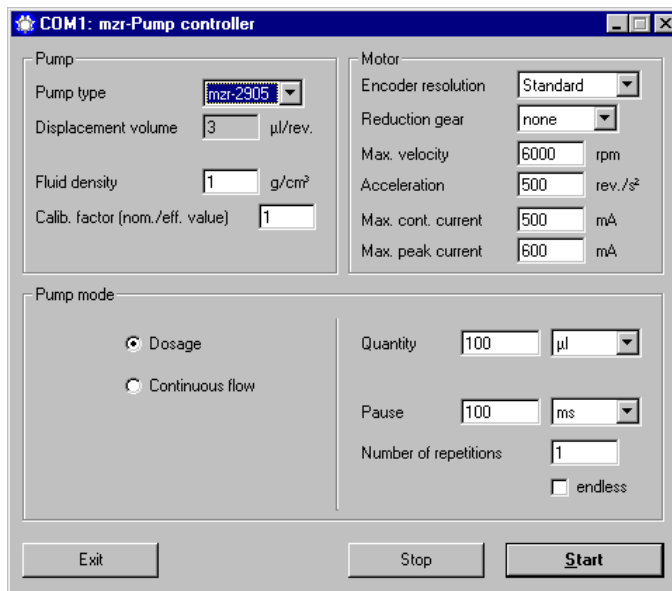

figure 26

Setup window of the »Dosage« operating mode

In the »Continuous flow« operating mode (see figure 27) continuous flow rates in units such as ml/min, g/min and rpm may be set. Operation of the micro annular gear pump may be initiated with the »Start« button or by pressing the enter key for the indicated »Duration« value. Checking of the »endless« box will put the pump to continuous operation. The »Stop« button or pressing of the enter key once again will stop the delivery. If you check the »Potentiometer« box, speed may be set by turning the potentiometer knob in the front of the control module or on the terminal box.

The input of the »Fluid density« enables to convert units of weight to the given volumes or to the given flow rates expressed in volume units. *Remark:* if you are only working with volumes, the indication of the fluid density will not be necessary and the standard value »1« can be left.

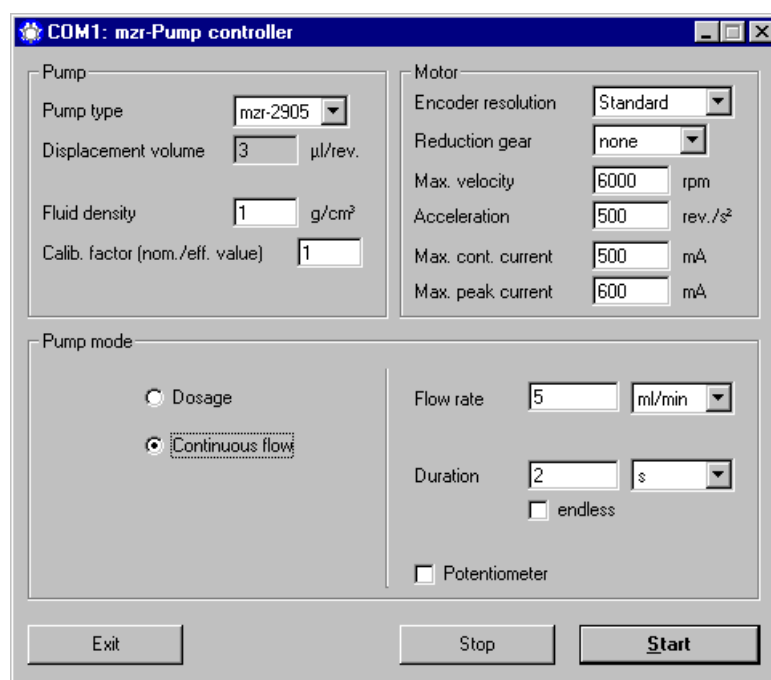

figure 27

Setup window of the »Continuous flow« operating mode

The »Calibration factor« enables to find the relation between the actually delivered quantities or flow rates (= actual value) and the set up quantities or flow rates (=nominal value). The calibration factor is specific to every pump and each application case and therefore should be determined by the user as according to the volume or weight of the delivered fluid. The calibration factor may be calculated according to the following formula:

$$\text{Calibration factor} = \frac{\text{Desired quantity}}{\text{Actual quantity}} = \frac{\text{Desired delivery value}}{\text{Actual delivery value}}$$

In practice, due to the high precision of the system the calibration factor value will only slightly exceed 1.

## 9 Software »Motion Manager«

The »Motion Manager« software enables operation and configuration of the drive and offers a possibility of an online graphic analysis of the operating data. The software is delivered on CD. The program may be installed on a PC running under Windows 7®, Windows 8 or Windows 8.1® operating systems.

Install the software »Motion Manager« by starting the program »Setup« from the CD.

If the CD are not available you may still download this program from the web site <http://www.hnp-mikrosysteme.de/download-center.html> or the web site [www.faulhaber.com](http://www.faulhaber.com) (menu support - download). Here, the latest version is always available in English and German.

After the installation the »Motion Manager« program may be loaded from the »Faulhaber Motors« folder from the Windows start menu.

In order to program the drive, the micro annular gear pump should be put into operation. The drive should be connected to the PC with the delivered null-modem cable.

### 9.1 Direct drive control

In the »Motion Manager« software the input commands may be sent directly to the drive. This enables to execute the movement commands and to modify the drive parameters.

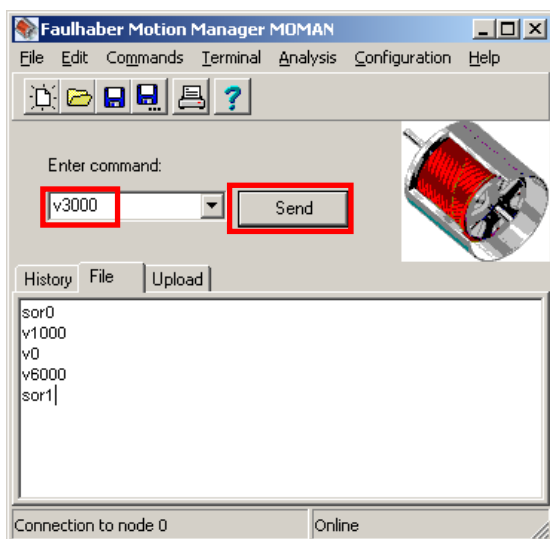

figure 28

Motion Manager software for direct control of the drive

The commands are entered in the field »Enter command:«. The button »Send« will send the command to the drive for execution (see figure 28). The commands may be given alternatively in capital letters or low case. The drive will ignore excess space characters.

### An example for continuous delivery

Commands	Description
SOR0	Operating mode RS-232: Set the nominal speed via the RS-232 interface
V1000	Rotation speed of 1000 rpm
V0	Standstill of the pump (speed 0 rpm)
V6000	Speed value 6000 rpm
SOR1	Analog input of the operating mode: setup of the nominal speed with the potentiometer knob or by connecting an external voltage signal to the analog input

### An example for discrete dosage

Command	Description
SOR0	Operating mode RS-232: set the position via RS-232 interface
LR10000	Load a relative position of 10000 to the control unit 10,000 = 10 rotations (Remark: 1000 steps = 1 rotation)
M	Execute the task / start positioning
LR20000	Load a relative position of 20000 to the control unit 20,000 = 20 rotations
M	Execute the task / start positioning
SOR1	Analog input operating mode: Set nominal speed with potentiometer or by connecting a voltage signal to the analog input

In case of the mzr-6355/mzr-7255 micro annular gear pump 1 revolution of the rotor corresponds to 1000 steps.

For more details concerning the operation of the Motion Manager, please read the online program help.

## 9.2 Programming of the control

The control of the micro annular gear pump may be adapted by the user to a specific task by means of an easy programming language. The program files are available in the ASCII code and have by default the »mcl« extension which stands for "*motion controller language*". Various parameters of the drive such as the maximal speed, the acceleration, the number of rotations, the allowable current load and the parameters of the PI-controller may be programmed with this language. Furthermore, it is possible to program short movement sequences which will be saved in the internal memory of the drive and then autonomously executed.

## 9.3 Transfer of a mcl file to the drive

The existing mcl files may be loaded to the file editor window using the menu command *File - Open...* (in the program window).

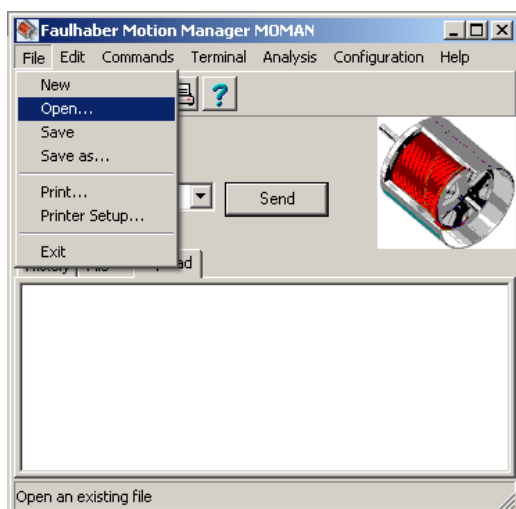

figure 29

Menu file- open

The required mcl file may be selected and loaded via the file selection window (see figure 29). By using the menu command *Terminal - Transfer configuration file* the mcl file will be transferred to the drive (see figure 30).

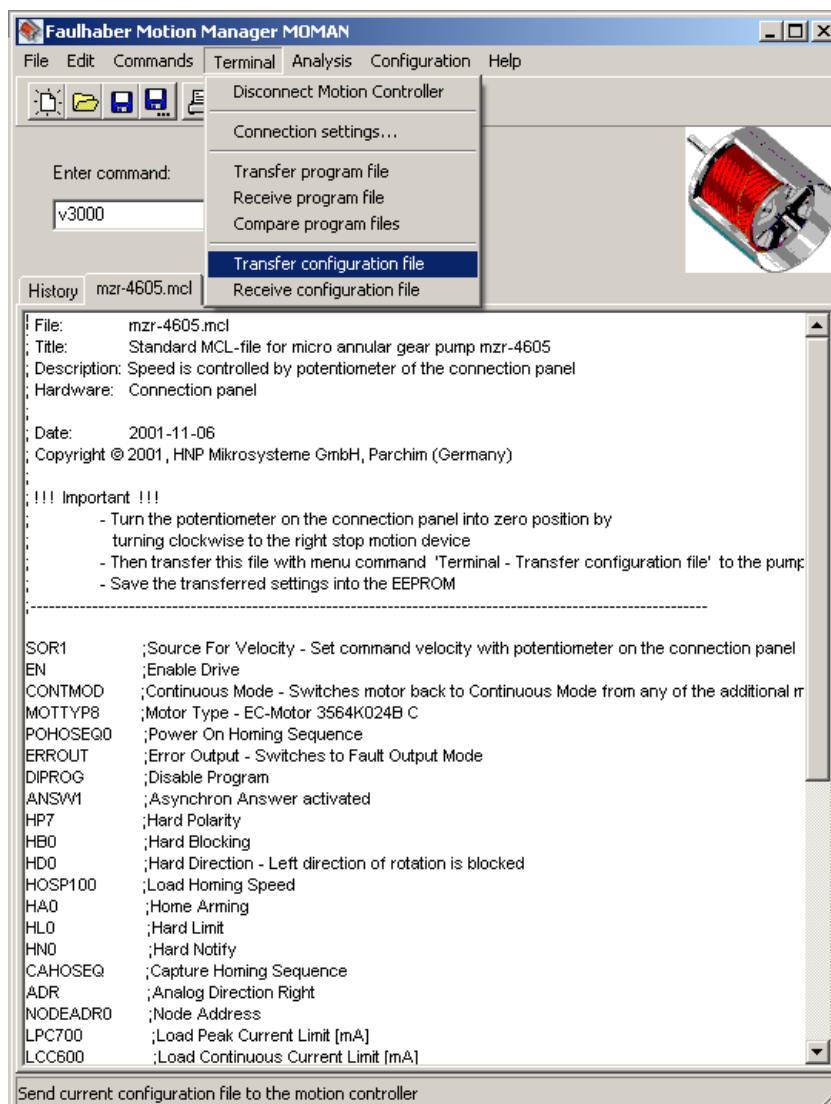

figure 30 Transfer of the mcl files as parameter data

When a window appears with the enquiry if the mcl files should be transferred to the »Motion-Controller«, answer by clicking on the »Yes« button.

In order to save the configuration and the programmed operation files in the EEPROM, confirm the dialogue window with »OK« (see figure 31). By this confirmation the program will be saved in the memory with a resident status and will be available for future operation.

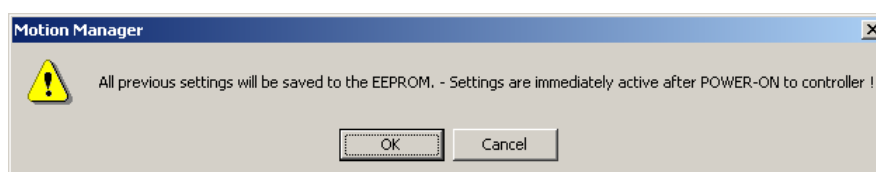

figure 31 Storage confirmation

A diskette with sample mcl programmes is delivered along with the Motion Manager. At the delivery the pump has a standard program configuration. Moreover, a sample program that may be started with an external switch is available for discrete dosage tasks.

<b>Pump type</b>	<b>Standard program</b>	<b>Sample program for dosage tasks</b>
mzs-6355	mzs-6355.mcl	switchdosage_6355_e3.mcl
mzs-7255	mzs-7255.mcl	switchdosage_7255_e3.mcl

table 23

Overview of mcl sample programs

## 10 Accessories for microfluidic systems

The accessory range for the liquid delivery systems of HNP Mikrosysteme comprises complementary equipment such as hoses, tubes, fluid fittings, filters and non-return valves that are best adapted to your micro annular gear pump. We will eagerly share our long date experience as far as component selection is concerned.

## 11 Non-liability clause

HNP Mikrosysteme GmbH shall not be liable any damage resulting from the non-respect of instructions comprised in this operating manual.

It belongs to the user to check the integrity, the correct choice and the suitability of the product for the intended use.

It remains at the responsibility of the user to conform to all laws, rules and regulations in force. This applies above all to the treatment of aggressive, poisonous, corrosive and other dangerous liquids.

## 12 Problems and their removal

Disturbance	Cause	Solution
1 The pump does not work.	No power supply	Check the power supply.
2 The pump does not pump the liquid.	No liquid in the primary tank	Fill the recipient/tank with liquid.
	Presence of air or gas in the pump	The pump cannot run dry against the system pressure. Fill in the pump at no pressure or at reduced system pressure.
	Malfunction of the liquid supply components (such as in the delivery tube, the needle or external non-return valve)	Check the components for possible disturbances to be eliminated. Cleanse the accessories where needed.
	Failure of the electric installation	Check the electric installation for the correct cable configuration, loose contacts, etc.
	The pump did not receive the start signal or start conditions are not fulfilled.	Check if the start condition have been fulfilled start signals (software control, PLC, start signal) and the programs.
3 The pump does not start to operate.	Motor disturbance: the red error LED is on.	Check the failure condition of the motor control with the Motion Manager software.
	The pump does not take in the liquid.	The tubing on the induction side is too long or has a too small internal diameter (a too low NPSHA value).
		The tubing or the fluid connection on the induction (suction) side are not tight. Please check the intake connection and the tubing.
		Air bubbles in the fluid system (tubes, valves, ...)
		If the viscosity of the liquid is too high, apply pressure on the suction side.
		Check the pressure exerted on the primary liquid tank.
		An external non-return valve does not open. Check the non-return valves.
Submit the non-return valve to a higher pressure, so that the pump may fill in.		
4 The motor turns, but the pump does not operate.	No liquid in the pump	Fill the pump with liquid.
	Air bubbles in the liquid supply system (tubing, valves, ...)	Fill the pump and the liquid supply system with liquid.
	The non-return valve does not open.	Rinse the non-return valve.
	Blocked delivery tubing or needle	Cleansing, flushing or exchange of the delivery tubing or dosage needle
	The coupling between the motor and the pump is out of position.	Return the pump to the manufacturer.
	The pump shaft is broken.	Return the pump to the manufacturer.
5 The pump is filled with liquid, but does not pump it.	Error indicator (the red status LED on the terminal box is on and the motor control has set the error output).	Check the motor error status with the Motion Manager software (command GFS). Try to liberate the pump by making it operate for 1 s in a reverse direction with -1000 rpm. Adapt the motor current to the control. Contact the manufacturer of the pump.
	Presence of particles in the delivered liquid or blockage of the pump.	Check the motor error status with the Motion Manager software. Try to liberate the pump by making it operate for 1 s in a reverse direction with -1000 rpm. Return the pump to the manufacturer for cleansing. Use a filter, flush the liquid delivery

Disturbance	Cause	Solution
		system.
		Flush the pump with a syringe.
	The non-return valve does not open.	Rinse the non-return valve.
	Blockage of the delivery tubing or the needle.	Cleanse, flush or exchange the delivery tubing or the needle.
	Air bubbles in the liquid delivery system, (tubing, valves)	Fill in the pump and the delivery system with liquid.
6 Dosage volume does not correspond to the set values.	Air bubbles in the liquid delivery system, (tubing, valves ,...) and the pump	Vent the liquid delivery system and check for untight fluid connections.
	Pump shows cavitation.	Too long or too narrow intake tubing. Shorten the intake tubing or change the position of the pump.
	Polluted or too small filter	Change the filter to a new or bigger one.
	The non-return valve does not open.	Rinse the non-return valve.
7 Speed of the pump cannot be adjusted.	Defective electric installation	Check the electric installation for correct cable configuration and loose contacts.
	Defective drive control	Return the drive control to the manufacturer.
8 Liquid drops from the dosing needle.	The non-return valve does not close.	Rinse the non-return valve.
	Too high pressure on the primary liquid tank	Stop the delivery of compressed air on the primary liquid tank.
	The liquid tank is placed at a higher level than the dosing needle.	Place the liquid tank at the same or slightly lower level than the pump.
9 The dosage volume decreases with time.	Polluted filter.	Exchange the filter.
	Deposits in the pump.	Flush the pump or return it to the manufacturer for dismantling and cleaning.
	The pump is worn after a long operating period or after use with abrasive liquids.	New definition of the calibration factor of the pump, by modifying the pump characteristics graph necessary.
10 Leakage from the pump	The sealing does not function correctly.	Return the pump to the manufacturer.
11 Leakage from the fluid connections	Untight lock rings	Exchange or tighten the fluid connections, exchange the fluid connection fittings.
12 Air bubbles on the delivery side	Loose fluid connections (particularly on the induction side)	Check and tighten the fluid connections.
	The shaft seal is untight or worn.	Return the pump to the manufacturer.
13 Minimal leakage during standstill	No error, cause relative to the operating principle	Employ a non-return valve. Place the liquid tank at the same or slightly lower level than the pump
14 Excess temperature	The surface of the pump is hot.	Clean the surface of the pump, rinse the pump
	The pump operates with difficulty.	The pump should be flushed.
	Particles in the delivered liquid or deposits in the pump	The operation of the pump should immediately be stopped! Return the pump to the manufacturer for cleansing.
	Noise of beveling	The operation of the pump should immediately be stopped! Return the pump to the manufacturer for cleansing and repair.
	The motor surface or the motor interior are too hot.	High temperature indicator in the drive is on. The motor has been shut down by the thermistor. Return the pump to the manufacturer.
15 The pump is noisy	Wearout of the pump or defective components	Do not continue to operate the pump, return it to the manufacturer for maintenance.
16 Lack of connection with the RS-232 interface	The pump is not connected.	Check the power supply 24 VDC.  Check the connection of the interface and the null-modem cable. Change the cable if necessary.

Disturbance	Cause	Solution
	The drive control does not respond.	Interrupt the voltage supply for about 10 s, connect the voltage supply again. Automatic start of the integrated drive control
17 Overcurrent	Particles in the delivered liquid	Rinse the pump.
	The pump operates with difficulty.	Dosing needle is damaged. Needle should be cleansed, flushed or exchanged. Tubing on the delivery side, dosing needle or non-return valve are blocked. Cleanse, flush or exchange the components.
	Deposits inside the pump.	Flush the pump. If necessary return the pump to the manufacturer.
18 Undervoltage	Voltage supply < 12 VDC	Check the power supply 24 VDC.
19 Overvoltage	Voltage supply > 28 VDC	Check the power supply 24 VDC. The drive control may be damaged. Return the pump to the manufacturer.

table 24

Problem shooting - causes and solutions.



If a disturbance that has not been mentioned in the above list, or that makes the use of the micro annular gear pump unsafe appears, please stop the operation of the pump without delay and contact the manufacturer.

## 13 EU Directive

A Directive or EU Directive is a legal instrument of the European Community addressing at the member states and forcing them to implement specific regulations or targets. Leastwise, micro annular gear pumps are covered, by the scope of application of the following Directives: The following directives are of importance for the user of the described micro annular gear pumps:

### **Low-Voltage Directive (2014/35/EU)**

The Low-Voltage Directive is not relevant for micro annular gear pumps described in this manual, because the supply voltage is limited to a maximum of 30 VDC.

### **Machinery Directive (2006/42/EU)**

A micro annular gear pump is a machine and is consequently covered by this Directive. However, it may be a part of a machine or installation.

### **EMC Directive (2014/30/EU)**

The Directive on Electromagnetic Compatibility (EMC) applies to all electronic and electrical devices, installations and systems. Consequently, the Motion Controller of the micro annular gear pump is covered by the EMC Directive.

### **RoHS Directive (2011/65/EU)**

To our knowledge our products delivered to you do not contain substances or applications in concentrations that are forbidden by this directive. No substances contain our products delivered to you after our current knowledge in concentrations or application, the placing on the market in products according to the valid requirements forbade to the Directive.

## WEEE Directive (2012/19/EU)



In Germany, the implementation of the WEEE Directive 2012/19/EU is regulated in the Electrical and Electronic Equipment Act (ElektroG). This law also holds the manufacturer responsible for the disposal of electrical and electronic equipment at the end of its life.

The symbol of the crossed-out wheeled bin on the electrical appliances indicates that they must not be disposed of with household waste, but require separate collection. Furthermore, we advise you to delete any existing personal data on the devices to be disposed of.

As a manufacturer, we offer our business customers (B2B) to take back and recycle all electrical equipment placed on the market according to certain ecological standards.

In order to avoid long logistics chains, we generally recommend giving old appliances to regionally based specialist disposal companies for disposal. Irrespective of this, HNP Mikrosysteme offers its business customers to send all devices of the brands mzr® that are in circulation in Germany to the following address at the end of their service life:

HNP Mikrosysteme GmbH | Brunnenstraße 38 | D-19053 Schwerin, Germany.  
Please inform us in advance via the e-mail address [service@hnp-mikrosysteme.de](mailto:service@hnp-mikrosysteme.de).

HNP Mikrosysteme GmbH will then ensure that they are disposed of in an environmentally friendly and legally compliant manner.

## REACH regulation (EU) No. 1907/2006

HNP Mikrosysteme is not a manufacturer or importer of chemical substances subjected to registration, but in terms of regulation, a downstream user. As downstream user, we conduct the necessary communication with our suppliers to ensure future deliveries of all components necessary to us. We will notify you of all relevant, changes in our products, their availability and the quality of parts/products delivered by us within our business and coordinate the appropriate action in individual cases with you. Previous inspection did not show any limitation in the supply of material from our upstream suppliers.

### 13.1 Electromagnetic Compatibility (EMC)

Electromagnetic compatibility is defined as the ability of a electric or electronic device to function satisfactorily as intended in its electromagnetic environment without introducing intolerable electromagnetic disturbances in that environment.

#### 13.1.1 EMC Directive and Standards

Comformity was proven by proof of compliance with the following harmonized standards by the company Dr. Fritz Faulhaber:

- EN 61000-6-4 (10/01): Generic standards – Emission standard for industrial environments
- EN 61000-6-2 (10/01): Generic standards – Immunity for industrial environments

These standards prescribe certain standardised tests for the emitted-interference and interference-immunity tests. The following tests are required due to the connections on the controller:

<b>Generic Standard on Emitted Interference:</b>	<b>Description</b>
EN 55011 (05/98)+A1(08/99)+A2(09/02):	Radio disturbance characteristics
<b>Generic Standard on Interference Immunity</b>	
EN 61000-4-2 (05/95)+A1(4/98)+A2(02/01):	Electrostatic discharge immunity test
EN 61000-4-3 (04/02)+A1(10/02):	Radiated, radio-frequency, electromagnetic field immunity test
EN 61000-4-4 (09/04):	Electrical fast transient/burst immunity test
EN 61000-4-5 (03/95)+A1(02/01)	Surge immunity test
EN 61000-4-6 (07/96)+A1(02/01):	Immunity to conducted disturbances, induced by radio-frequency fields
EN 61000-4-8 (09/93)+A1(02/01):	Power frequency magnetic field immunity test

table 25

Standards Summary

All tests were conducted successfully.

### 13.1.2 Information on use as intended

For micro annular gear pumps, note the following:  
Requirement for the intended operation is the operation according to the technical data and the manual.

#### Restrictions

If the micro annular gear pumps are used at home, in business or in commerce or in small businesses, appropriate measures must be taken to ensure that emitted interferences are below the permitted limit a values!

#### Installation instructions:

The power supply and motor supply cable must be connected directly to the terminal box S-G05.

During the operation of micro annular gear pumps with a multiplexer board the connection of the terminal box S-G05 is not possible.

## 14 Declarations of conformity

The delivered micro annular gear pump falls within scope of the following EU directives:

- Machinery Directive (2006/42/EU)
- EMC Directive (2014/30/EU)

You may request the declarations of conformity for the micro annular gear pumps from us separately.

## **Declaration of EU-Conformity**

### Machinery Directive 2006/42/EU

We hereby declare that the following micro annular gear pumps of the hermetic inert pump series:

**mzr-6355, mzr-7255**

are intended for installation into another machinery/plant and that start of operation is forbidden until it is identified that the machinery/plant into which these micro annular gear pumps shall be installed corresponds to the regulations of the EU guidelines regarding safety and health requirements.

We confirm the conformity of the product described above to the following standards in terms of applied directives

- Machinery Directive (2006/42/EU)

Applied standards are particularly

DIN EN 809	DIN EN 60204-1	DIN EN 294
DIN EN ISO 12100 part 1		DIN EN 953
DIN EN ISO 12100 part 2		UVV

This statement does not warrant any characteristics in terms of product liability. Please note the safety instructions in the manual.

Mr. Lutz Nowotka, HNP Mikrosysteme GmbH, Bleicherufer 25, D-19053 Schwerin is authorised to compile the technical file according to Annex VII A.

Date: December 30, 2023

Signature manufacturer:

Dr. Thomas Weisener  
CEO



## **Declaration of EU-Conformity**

EMC Directive 2014/30/EU

We hereby declare that the following micro annular gear pumps of the hermetic inert pump series:

**mzr-6355, mzr-7255**

are intended for installation into another machinery/plant and that start of operation is forbidden till it is identified that the machinery/plant into which these micro annular gear pumps shall be installed corresponds to the regulations of the EU guidelines regarding safety and health requirements.

We confirm the conformity of the product described above to the following standards in terms of applied directives

– EMC Directive (2014/30/EU)

Applied standards are particularly

EN 61000-6-4 (10/01): Generic standards – Emission standard for industrial environments

EN 61000-6-2 (10/01): Generic standards – Immunity for industrial environments

This statement does not warrant any characteristics in terms of product liability. Please note the safety instructions in the manual.

Date: December 30, 2023

Signature manufacturer:

Dr. Thomas Weisener  
CEO



## 15 Service, maintenance and warranty

The maintenance of the micro annular gear pump should be carried out depending on the delivered liquid

- *for lubricating liquids* after 12,000 h working hours, but not later than 24 months after the initial operation
- *for non-lubricating liquids, crystallizing liquids or liquids containing particles*, after 5000 h working hours but not later than 12 months after the initial operation. If during the first inspection no substantial wearout of the pump is observed, the following inspection under the same working conditions should be performed after 8000 h working hours, yet not later than 15 months following to the last inspection.

If during the first inspection the pump shows a particularly strong wearout, the maintenance intervals should be readapted to the operating parameters.

In order to prevent a strong wearout of the pump, the pump should be shut down properly after every application as described in the chapter 7.4. A supplementary flushing procedure with a neutral flushing liquid (see chapter 7.3) also slows down the wearout process of the pump.



It is not allowed to open the micro annular gear pumps. The warranty extinguishes with the expiry of the legal warranty period or with the opening of the pump. Furthermore HNP Mikrosysteme cannot give any warranty of exchange for parts whose damage result from incorrect use.



For service and maintenance please return your micro annular gear pump to HNP Mikrosysteme (You will find the address on the cover of the present operating manual).



The declaration of liquids having had contact with the micro annular gear pump and components must imperatively be completed. The nature of the liquids must be specified. In case of non-compliance the sender will be liable for any resulting injure to persons or any object damage.



Sealings, rotors and shaft are parts that undergo wear and will be replaced by HNP Mikrosysteme GmbH during maintenance depending on their degree of wear.

## 16 Contact person

### **Development and application assistance , service and accessories**

Mr. Sven Reimann  
Phone +49| (0) 385|52190-349

### **Service and maintenance**

Mr. Ronny Haberland  
Phone +49| (0) 385|52190-325

### **Drive and control technology**

Mr. Lutz Nowotka  
Phone +49| (0) 385|52190-346

## 17 Legal information

### Marks

mzr® is a registered German trademark of HNP Mikrosysteme GmbH.

MoDoS® is a registered German trademark of HNP Mikrosysteme GmbH.

µ-Clamp® is a registered German trademark of HNP Mikrosysteme GmbH.

HNPM® is a registered German trademark of HNP Mikrosysteme GmbH.

Teflon® is a registered trademark of DuPont.

Viton® is a registered trademark of DuPont Dow Elastomers.

Kalrez® Spectrum™ is a registered trademark of DuPont.

PEEK™ is a registered trademark of Victrex plc.

HASTELLOY® is a registered trademark of Haynes International, Inc.

Aflas® is a registered trademark of ASAHI Glass Ltd.

Microsoft®, Windows® are registered trademarks of Microsoft Corporation in the USA and in the other countries.

Cavro® is a registered trademark of Tecan Systems, Inc.

Other product names or descriptions not mentioned above are possibly registered trademarks of related companies.

### Patents

Micro annular gear pumps (and housings) are protected by assigned patents: EP 1115979 B1, US 6,520,757 B1, EP 852674 B1, US 6,179,596 B1, EP 1354135, US 7,698,818 B2. Patents pending DE 10 2011 001 041.6, PCT/IB2011/055108, EP 11 81 3388.3, US 13/884,088, CN 2011 8006 5051.7, HK 13 11 2934.9, DE 10 2011 051 486.4, PCT/EP2012/061514, EP 12 728264.8, US 9,404,492 B2, CN 2012 8003 8326.2. In the US, Europe and China additional patents are pending.

## 18 Safety information for the return of already employed micro annular gear pumps and components

### 18.1 General information

The operator carries the responsibility for health and safety of his/her employees. The responsibility extends also to employees not belonging to the company that have a direct contact with the micro annular gear pump and its components during repair or maintenance works. The nature of media (liquids) coming into contact with the micro annular gear pump and its components must be specified in the corresponding declaration form.

### 18.2 Declaration of liquids in contact with the micro annular gear pump

The staff performing the repair or maintenance works must be informed about the condition of the micro annular gear pump before starting any work on the device. The »Declaration of media in contact with the micro annular gear pump« should be filled in for this purpose.

The declaration should be sent directly to the supplier or to the company designated by the supplier. A second copy of the declaration must be attached to the shipment documents.

### 18.3 Shipment

The following instructions should be observed for the shipment of the micro annular gear pump.

- drain any remaining liquid from the pump
- flush the pump with an adapted flushing liquid
- remove the filter elements from the integrated or loosely delivered filters
- all the openings should be air-tight plugged
- return the pump in the original packing

## 19 Declaration of media in contact with the micro annular gear pump and its components

### Type of the device

Pump type/article no.: \_\_\_\_\_  
Serial number: \_\_\_\_\_  
Operating hours/running time: \_\_\_\_\_  
Reason of return: \_\_\_\_\_  
\_\_\_\_\_  
\_\_\_\_\_

### Contact with media (liquids)

The micro annular gear pump was in contact with: \_\_\_\_\_

and has been rinsed with: \_\_\_\_\_

Product info sheet / Material Safety Data Sheet:  yes\*  no \* Please attach file

or is available on the following web site: www. \_\_\_\_\_

If a pump which had contact with dangerous substances could not be properly cleansed prior to shipment, we reserve the right to entrust a specialized company with cleansing of the device. The return of the pump in original packing is advisable. It is necessary in order to protect the employees and delivery staff.

Nature of media contact:

- |   |  |  |
|---|--|--|
| <input type="checkbox"/> explosive                | <input type="checkbox"/> oxidizing       | <input type="checkbox"/> sensitive to moisture |
| <input type="checkbox"/> toxic (toxic byproducts) | <input type="checkbox"/> radioactive     | pH-value: approx. _____ to _____               |
| <input type="checkbox"/> carcinogenic             | <input type="checkbox"/> microbiological | other: _____                                   |
| <input type="checkbox"/> irritant                 | <input type="checkbox"/> corrosive       | _____  |

Hazard (H-statements): \_\_\_\_\_ Precautionary (P-statements): \_\_\_\_\_

### Declaration

Hereby I/we affirm that the stated information is complete and correct. Micro annular gear pump and accessories are shipped in conformity with the applicable regulations.

company: \_\_\_\_\_  Mrs  Mr title: \_\_\_\_\_  
division: \_\_\_\_\_ name: \_\_\_\_\_  
street, no.: \_\_\_\_\_ phone: \_\_\_\_\_  
ZIP/city: \_\_\_\_\_ e-mail: \_\_\_\_\_  
country: \_\_\_\_\_

city, date: \_\_\_\_\_ authorized signature /  
company stamp:

## 20 Appendix

- Drawing
- Technical manual for Faulhaber motor 3564K024BCS
- Communication and function manual for Faulhaber motor 3564K024BCS

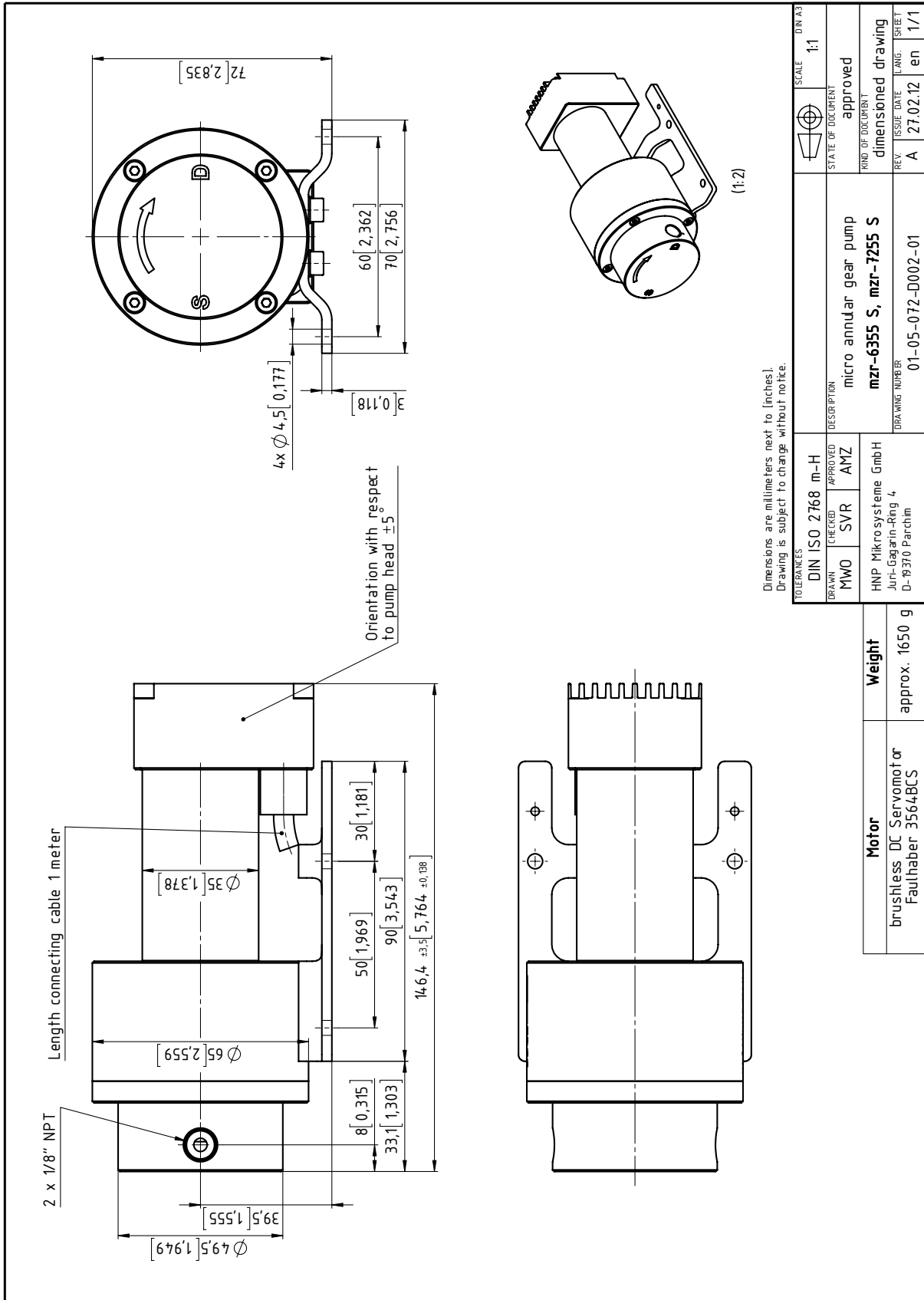

figure 32

Drawing mZR-6355S/7255S

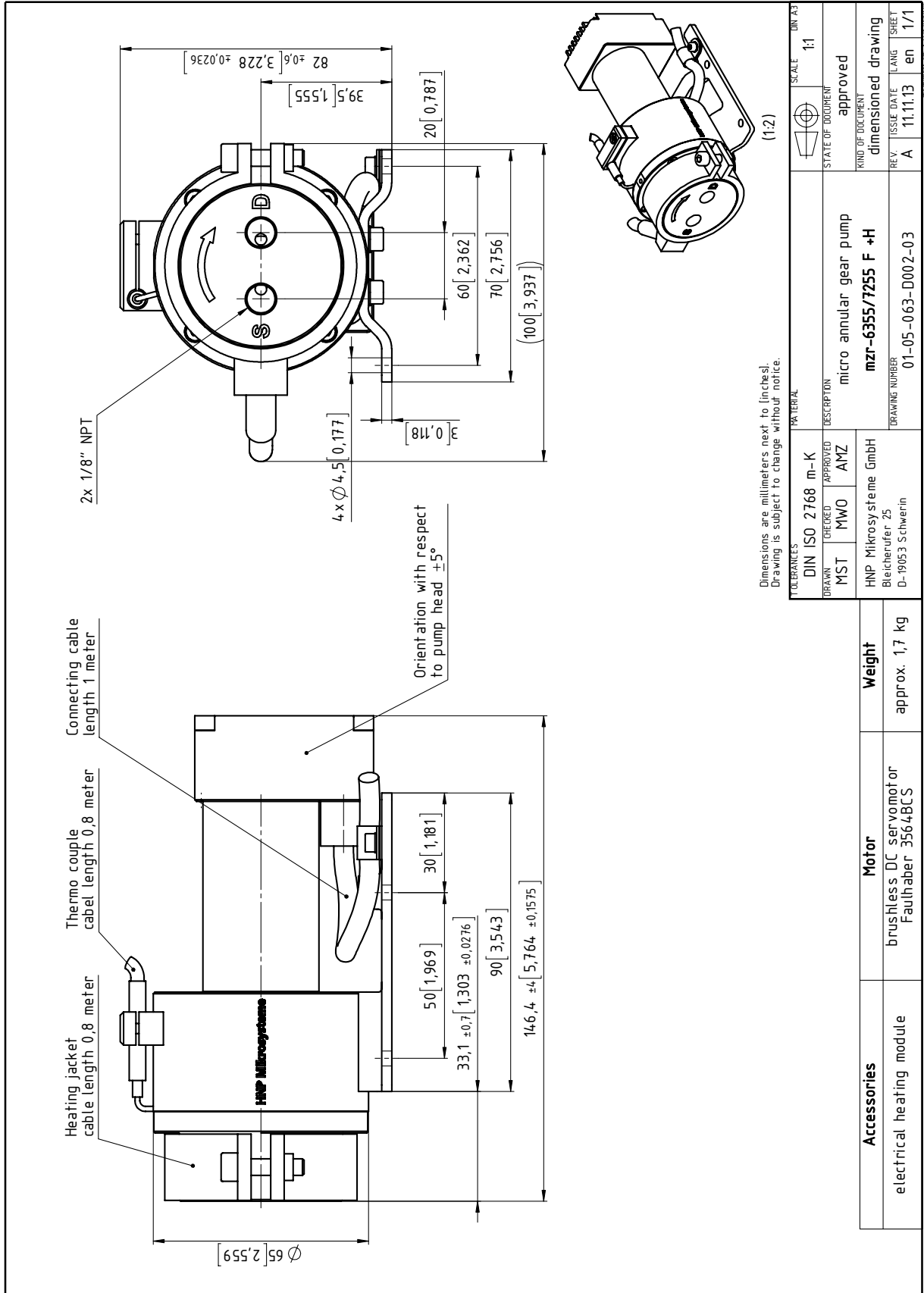

figure 33

Drawing mzs-6355S/7255F