

Quick Guide Inline Filter F-MI3-T

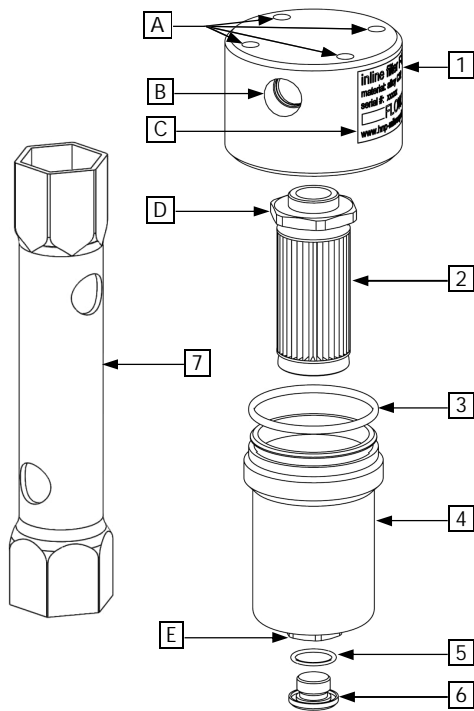

Technical Data

| Dimensions | Value | Pressures | max. Value |
|--|---|-----------------------|-----------------------|
| Filter area (depends on filter tissue) | approx. 135...150 cm ² (20,93...23,25 sq.in.) | Operating pressure | 200 bar (2900 psi) |
| Dimensions (Ø x H) | Ø 70 x 114 mm (Ø 2,76 x 4,49 in.) | Differential pressure | 20 bar (290 psi) |
| Empty volume | 92 ml (5,61 cu.in.) | | |

Items and descriptions

| Item no. | Description | Stainless steel (-s) | Alloy C22 (-y) |
|----------|---|---|----------------------------|
| 1 | Filter head | 1.4404 | 2.4602 |
| 2 | Filter element (mesh sizes) | 1.4404, 1.4571 (3, 10, 25, 40, 100 µm) | 2.4602 (10, 40, 100 µm) |
| 3 | O-ring Ø 45,69 x 2,62 mm | refer to table "Sealing materials..." below | |
| 4 | Filter housing | 1.4404 | 2.4602 |
| 5 | O-ring Ø 15,1 x 1,6 | refer to table "Sealing materials..." below | |
| 6 | Drain plug G 1/4" | 1.4404 | 2.4602 |
| 7 | Deep socket wrench AF 32 (optional available, item No. 92 00 29 09) | | |
| A | Mounting holes M8 (4 times) | | |
| B | Fluid connection 3/8" NPT (2 times, only inlet port shown) | | |
| C | Label with specifications and flow direction | | |
| D | Hexagon bolt AF 32 | | |
| E | Hexagon bolt AF 21 | | |

Sealing materials and Operating temperature ranges

| Sealing material | Temperature range |
|--|-------------------------------|
| -v FPM | -15...+200 °C (+5...+392 °F) |
| -e1 EPDM (FDA compliant) | -50...+140 °C (-58...+284 °F) |
| -f2 FFPM (Kalrez® Spectrum™ 6375) | -20...+275 °C (-4...+527 °F) |
| -f3 FFPM (Kalrez® 6221, FDA compliant) | -15...+260 °C (+5...+500 °F) |
| -f4 FFPM (Perlast® ICE G90LT) | -46...+240 °C (-51...+464 °F) |
| -f5 FFPM (Kalrez® Spectrum™ 7075) | -20...+327 °C (-4...+500 °F) |
| -f7 FFPM (Chemraz® 505) | -20...+275 °C (-4...+527 °F) |

⚠ Safety instructions

All of the following tasks must be carried out only by professional and qualified personnel.

The filter must be operated within its specifications. Manipulation, misuse and damaging of the filter are forbidden.

It is only allowed to use original-spare parts.

The internal safety instructions for the used medium must be observed.

Installation/Assembly

- The filter should be placed upstream of the component to be protected (i.e. pump)
- Use the mounting holes [A] to mount the filter in the system – the filter housing [4] must point downwards
 - ⚠ Attention! Fastening the filter only by the fluidic connections [B] is not allowed!
- Ensure a tension free connection of the system tubing to the fluidic connections [B]
 - ⚠ Attention! Basically, for fluidic connectors with NPT-threads use an appropriate thread sealant (i.e. PTFE-tape)!
 - ❗ Instead of the drain plug [6] you can also connect a drain line to the G 1/4"-thread.

Commissioning

- Ensure media supply
- Switch on the system

Decommissioning

- Ensure system is shut down, depressurized and eventually cooled down
- Interrupt media supply

Exchange of filter element

- Required tools / assistive equipment: thread lubricant, Allen wrench size width across flats (AF) 5, screw-wrench AF 21, deep socket wrench AF 32 [7]
- Decommissioning (see above)
- Unscrew drain plug [6] carefully with Allen wrench AF 5 out of filter housing [4]. If necessary, hold filter housing [4] at the hexagon bolt AF 21 [E]
- Capture drain plug [6] and rests of liquid
 - ⚠ Attention! The drain plug comes with an O-ring [5]!
- Unscrew filter housing [4] at the hexagon bolt AF 21 [E] out of the filter head [1]
- Put the deep socket wrench [7] over the filter element [2] until it engages with the width across flats [D]. Unscrew filter element [2] from the filter head [1].
- Clean all parts and inspect for damage (especially seals [3], [5] and threads) – replace components if necessary
- Carefully insert the new or cleaned filter element [2] by hand into the filter head [1]
 - ⚠ Attention! Do not tighten by hand (possible deformation)!

- Put the deep socket wrench [7] over the filter element [2] until it engages the width across flats [D]. Fasten the filter element [2] hand-tight
- Insert the drain plug [6] including O-ring [5] into the filter housing [4] and fasten it hand-tight with the Allen wrench AF 5
- Apply thread lubricant on the thread of the filter housing [4]
- Moisten the O-ring [3] with volatile medium such as demineralized water or isopropanol (alternatively with the conveying medium or thread lubricant)
 - ⚠ Attention! An assembly without lubricant can lead to damage to threads and O-rings!
- Screw the filter housing [4] carefully by hand into the filter head [1]
 - ❗ For a faster commissioning, the filter housing [4] can be filled in advance with liquid to about 2/3.
- Screw the filter housing [4] by the hexagon bolt AF 21 [E] until limit stop, then unfasten 1/4 of a turn
 - ⚠ Attention! The thread of the filter housing [4] must no longer be visible!
- Perform a pressure test and make a visual inspection of all sealing points
- Commissioning (see above)

Contact

HNP Mikrosysteme GmbH
Bleicherufer 25 · D-19053 Schwerin

phone +49 385 52190-301
fax +49 385 52190-333

e-mail info@hnp-mikrosysteme.de
http://www.hnp-mikrosysteme.de