

## Product information

### mzr-7243 · Modular pump series

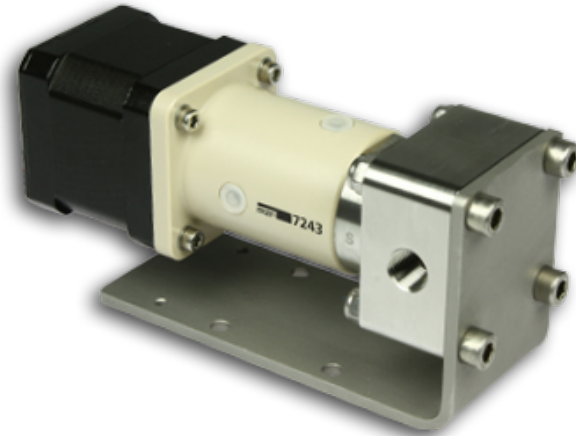

#### Description

The micro annular gear pump mzr-7243 of the modular pump series is suitable for dosing and metering in low to medium pressure and viscosity ranges. To the main assets of this series belong low pulsation, high precision low volume dosage of non-lubricating liquids, compact design with smallest dimensions and low price. These pumps are suitable for dosing and dispensing deionized water, aqueous solutions, solvents as well as low to highly viscous oils, lubricants or dyes

#### Advantages

- Customized material selection pump components in stainless steel/tungsten carbide, aluminium/tungsten carbide or alloy C22/ceramics
- High dosage precision precision CV 1 % at low volumes
- Dynamic powerful small drive stepper motor, high torque
- Long service life wear- and corrosion-resistant materials
- Low pulsation delivery, low shear stress rotary micro annular gear technology

#### Applications

- Chemical processing
- Industrial and plant engineering
- Packaging
- Dispensing of adhesives

## Technical data

Flow rate	0.048 - 28.8 ml/min
Smallest dosage volume	30 µl
Displacement volume	48 µl
Differential pressure range	0 - 5 bar (73 psi), max. 40 bar * (max. 580 psi *)
Maximum inlet pressure	1 bar (15 psi), max. 5 bar * (max. 73 psi *)
Liquid temperature range	-20 ... +60 °C (-4 ... +140 °F)
Viscosity range	0.3 - 10,000 (0.3 - 50,000*) mPas
Precision CV	1 % (Coefficient of variation CV)
Velocity range	1 - 600 rpm
Fluid connection	1/8" NPT internal thread, lateral; optional: flanged connection with pipe socket, frontal
Wetted parts	Pump case: stainless steel 316L, optional: aluminium anodized, alloy C22; rotors: tungsten carbide Ni-based, optional: ceramics; bearing: ceramics, epoxy resin; shaft seal: graphite-reinforced PTFE, stainless steel 316L; static seals: FPM, optional: EPDM, FFPM
Motor	stepper motor NEMA 17 standard
Dimensions (L x W x H)	approx. 128 x 42 x 60 mm
Weight	approx. 815 g (aluminium version approx. 560 g)
Remarks	* with optional additional axial bearing support; Customized solutions on request.

### Notice

Even if single parameters are within the indicated performance range of technical data, certain parameter combinations may not be achievable. Single parameters may exceed their indicated performance range under adequate circumstances. For detailed evaluation please contact HNP Mikrosysteme. Actual performance may vary. Specifications are subject to change without notice. This document is subject to change without notice.

## Accessories

- Reservoir Plastic
- Additional axial bearing support

## Dimensions

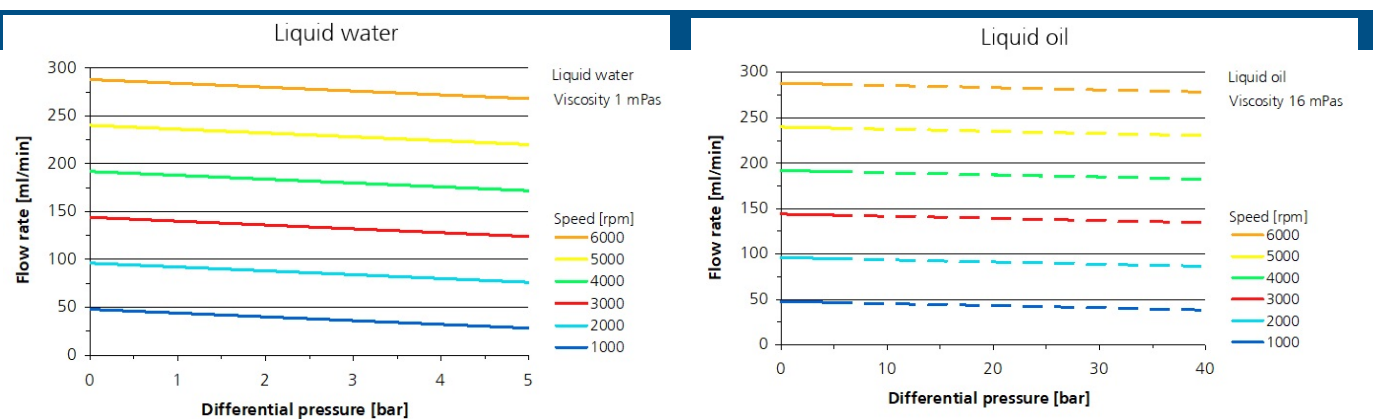
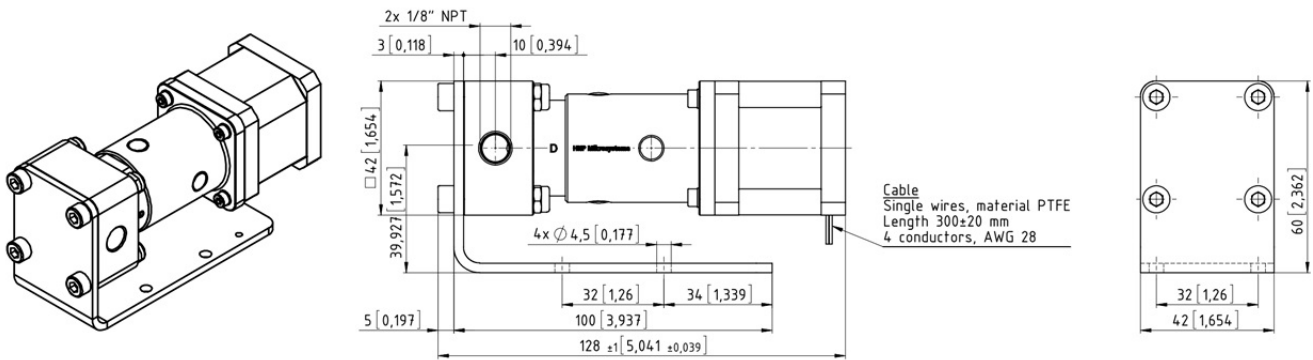

## Patents and trademarks

Micro annular gear pumps (and housings) are protected by assigned patents: EP 1 354 135 B1; US 7,698,818 B2; DE 10 2011 001 041 B4; CN 103 348 141 B; US 10,012,220 B2; CN 103 732 921 B; US 9,404,492 B2; US 6,520,757 B1.

HNP M<sup>®</sup>, mzi<sup>®</sup>, MoDoS<sup>®</sup>,  $\mu$ -Clamp<sup>®</sup>,  $\mu$ Dispense<sup>®</sup>, Centifluidic Technologies<sup>®</sup>, LiquiDoS<sup>®</sup>, smartDoS<sup>®</sup>, colorDoS<sup>®</sup> are registered German trademarks of HNP Mikrosysteme GmbH.

## Contact

HNP Mikrosysteme GmbH  
Bleicherufer 25  
19053 Schwerin  
Germany

T +49 385 52190-300  
F +49 385 52190-333  
sales@hnp-mikrosysteme.de

Last update 2024/01