

## Product information

### mzr-6359X2 Ex · Ex-versions



#### Description

The micro annular gear pump mzr-6359X2 Ex of the hermetic inert pump series in its explosion proof version is used for highly precise, low pulsation small volume dosage even of aggressive and corrosive liquids. The compact design combined with high achievable pressures are unique features. The pumps are applied in the field of chemical and process technology. Thanks to the use of rotors and functional elements being made of ceramics, a magnetic coupling, and case components made out of alloy C22, this pump will take up any challenge in the chemical industry applications.

#### Advantages

- Ex-certification ATEX conform with EU Directive 2014/34/EU
- Precision motor and sophisticated control ATEX DC-servomotor with integrated microcontroller
- Compact, chemically inert length 354 mm, alloy C22, SSiC, Al2O3 and ZrO2 ceramics
- Hermetically sealed magnetic coupling (NdFeB)
- High dosage precision precision CV < 1 % at low volumes
- Low pulsation delivery, low shear stress rotary micro annular gear technology, no valves

## Dimensions

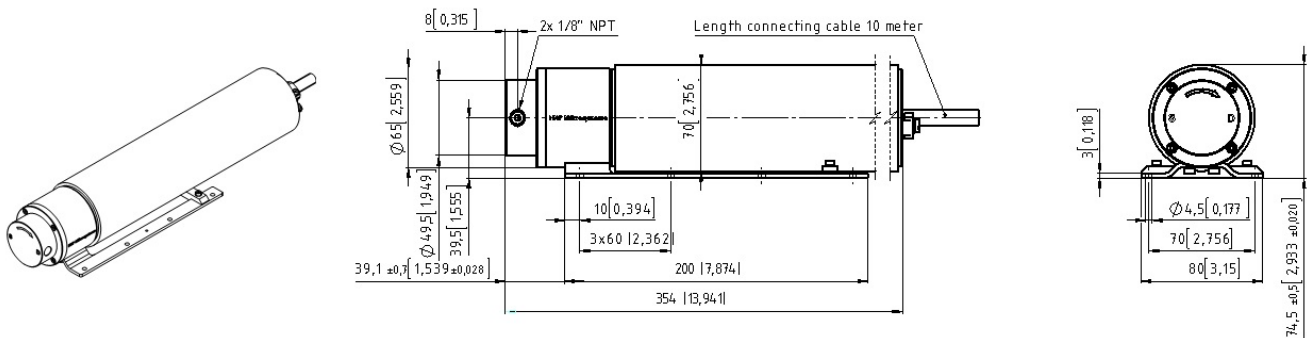

## Technical data

Flow rate	0.024 - 96 ml/min
Smallest dosage volume	15µl
Displacement volume	24µl
Differential pressure range	0 bar (73 psi), (40 bar (580 psi) *)
Maximum inlet pressure	80 bar (1160 psi) (inlet pressure + differential pressure)
Ambient temperature range	0 ... +40 (+32 ... +104 °F)°C
Liquid temperature range	-5 ... +60 °C (+23 ... +140 °F), -20 ... +120 °C * (-4 ... +248 °F)
Viscosity range	0.3 - 100 mPas
Precision CV	< 1% (Coefficient of variation CV)
Ex-certification	CE Ex II 2G IIC c T4 X
Place of installation	Ex-area zone 1, 2
Fluid connection	1/8" NPT internal thread, lateral
Wetted parts	Pump case alloy C22 (DIN 2.4602), optional: stainless steel 316L; seals FFPM (Kalrez® Spectrum™ 6375), optional: FPM, EPDM; shaft/bearing sintered silicon carbide (SSiC); bearing and wetted functional parts Al2O3 ceramics; rotors partially stabilized ZrO2, optional: tungsten carbide Ni-based
Motor	BLDC motor with integrated motion controller, 24 V DC, 2 A, 53 W, analog hall sensors (3000 pulses / revolution)
Velocity range	1 - 4,000 rpm
Cable length	10m
Weight	approx. 4,900 g
Remarks	* with optional heat insulation module; Customized solutions on request.

### Notice

Even if single parameters are within the indicated performance range of technical data, certain parameter combinations may not be achievable. Single parameters may exceed their indicated performance range under adequate circumstances. For detailed evaluation please contact HNP Mikrosysteme. Actual performance may vary. Specifications are subject to change without notice.

## Accessories

- Terminal box S-G05
- Heat insulation module
- mzs-Touch Control

## Flow charts

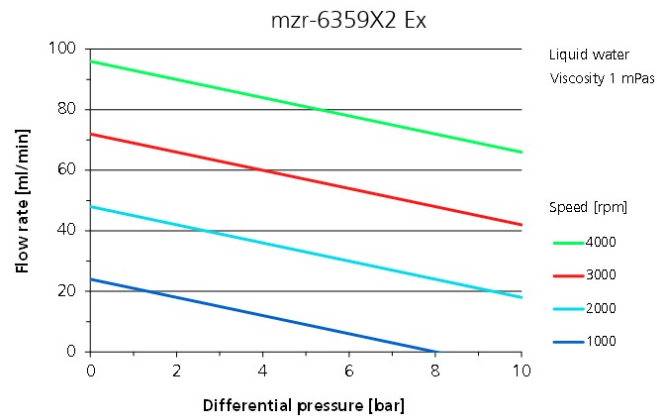

## Patents and trademarks

Micro annular gear pumps (and housings) are protected by assigned patents: EP 1 354 135 B1; US 7,698,818 B2; DE 10 2011 001 041 B4; CN 103 348 141 B; US 10,012,220 B2; CN 103 732 921 B; US 9,404,492 B2; US 6,520,757 B1.

HNP M<sup>®</sup>, mzr<sup>®</sup>, MoDoS<sup>®</sup>,  $\mu$ -Clamp<sup>®</sup>,  $\mu$ Dispense<sup>®</sup>, Centrifluidic Technologies<sup>®</sup> are registered German trademarks of HNP Mikrosysteme GmbH.

## Contact

HNP Mikrosysteme GmbH  
Bleicherufer 25  
19053 Schwerin  
Germany

T +49 385 52190-300  
F +49 385 52190-333  
info@hnp-mikrosysteme.de

Last update 2019/07