

Product information

mzr-11508 · High performance pump series

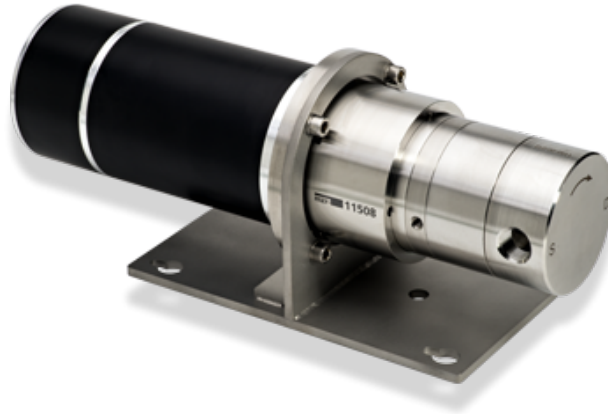

Description

The micro annular gear pump mzr-11508 is equipped with tungsten carbide rotors and bearings. Hard construction material and precision manufacturing techniques guarantee excellent dosage precision, high service life and wear resistance for low volume dosage of non-lubricating liquids. Driven by a high-power DC-motor the pump has a compact design and covers the flow range from 0.19 ml/min to 1152 ml/min. The mzr-11508 is suitable for continuous delivery and discrete dosage of low and high viscosity liquids. It achieves high differential pressures and provides a low pulsation flow. Its robustness and the available accessories make it suitable for challenging applications.

Advantages

- High dosage precision
precision CV < 1% at low volumes
- Long service life
wear-resistant tungsten carbide
- Broad viscosity range
methanol, water, solvents, adhesives, grease, gel
- Dynamic precision motor
brushless DC-motor with encoder
- Compact dimensions
length 313 mm
- High differential pressures
achievable even for low viscosity liquids
- Low pulsation delivery, low shear stress
rotary micro annular gear technology

Applications

- Chemical processing
- Industrial and plant engineering
- Packaging
- Medical and pharmaceutical industry
- Mini plant technology
- Spraying
- Dispensing of adhesives
- Ink and paint dosage
- Vacuum applications

Technical data

Flow rate	0.19 - 1,152 ml/min
Smallest dosage volume	100µl
Displacement volume	192µl
Differential pressure range	0 – 100 bar
Maximum inlet pressure	10 bar
Liquid temperature range	-5 ... +60 °C (-20 ... +120 °C *) (+23 ... +140 °F (-4 ... +248 °F))
Viscosity range	0.3 - 150,000 mPas
Precision CV	< 1% (Coefficient of variation CV)
Velocity range	1 - 6,000 rpm
Fluid connection	3/8" NPT internal thread, lateral optional 3/8" NPT internal thread, frontal
Wetted parts	stainless steel 316L (1.4435), tungsten carbide Ni-based; shaft seal: graphite-reinforced PTFE, alloy C276 (2.4819); static seals: FPM, optional: EPDM, FFPM
Motor	Brushless DC-motor, IP 54, 42 V DC, max. 368 W
Encoder	500 counts per turn, type HEDL 5640
Electrical connection	motor cable length 3 m, 6-pole plug for motor winding, 12-pole plug for encoder and hall sensors
Dimensions (L x W x H)	313 x 110 x 125 mm
Weight	approx. 8,000 g
Remarks	* with optional heat insulation or heating module, Customized solutions on request.

Notice

Even if single parameters are within the indicated performance range of technical data, certain parameter combinations may not be achievable. Single parameters may exceed their indicated performance range under adequate circumstances. For detailed evaluation please contact HNP Mikrosysteme. Actual performance may vary. Specifications are subject to change without notice.

Accessories

- Heat insulation module
- Electrical heating module
- S-HV
- Reservoir Plastic
- Double shell heating module
- S-HP-E

Dimensions

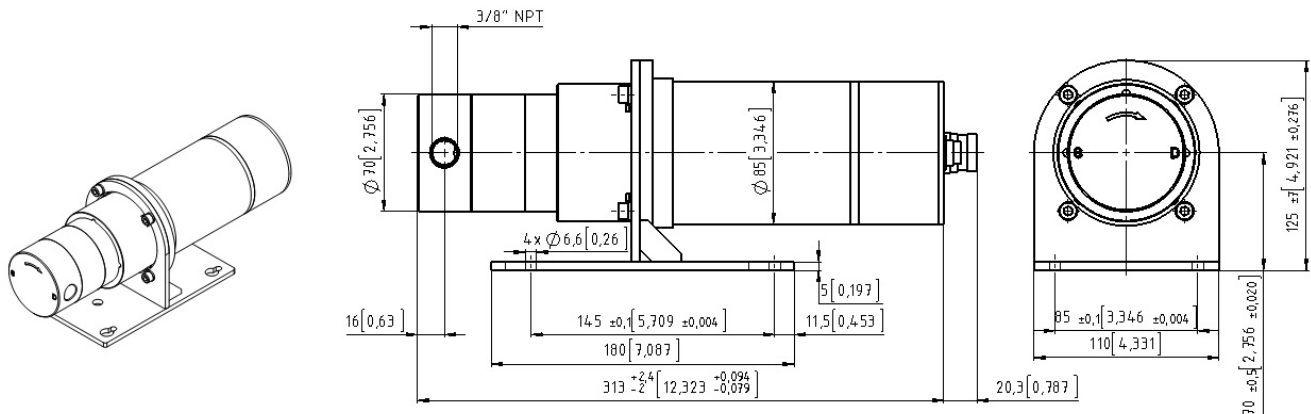

Flow charts

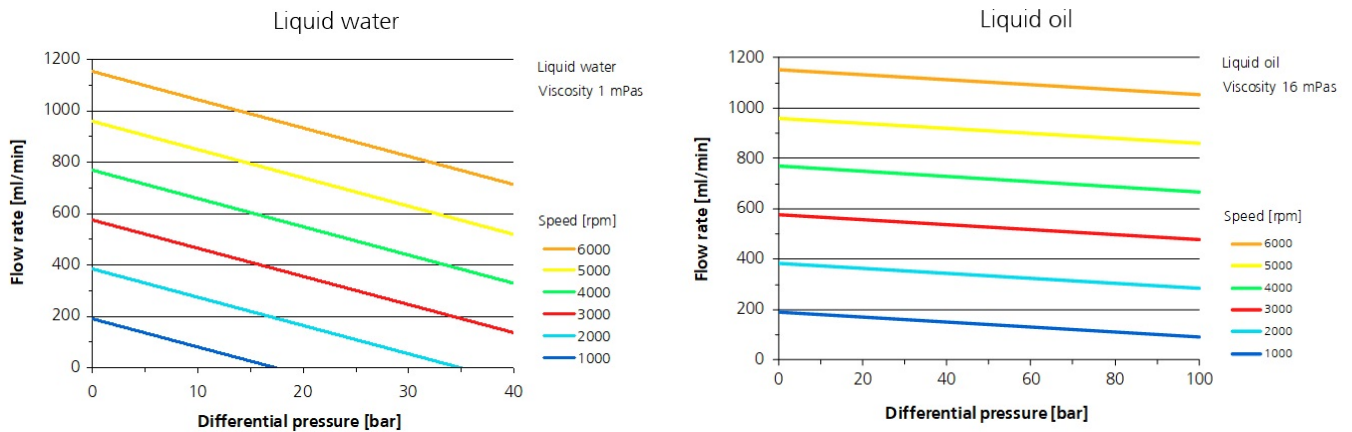

Patents and trademarks

Micro annular gear pumps (and housings) are protected by assigned patents: EP 1 354 135 B1; US 7,698,818 B2; DE 10 2011 001 041 B4; CN 103 348 141 B; US 10,012,220 B2; CN 103 732 921 B; US 9,404,492 B2; US 6,520,757 B1.

HNPM[®], mzr[®], MoDoS[®], µ-Clamp[®], µDispense[®], Centifluidic Technologies[®] are registered German trademarks of HNP Mikrosysteme GmbH.

Contact

HNP Mikrosysteme GmbH
Bleicherufer 25
19053 Schwerin
Germany

T +49 385 52190-300
F +49 385 52190-333
info@hnp-mikrosysteme.de

Last update 2019/07