

## Product information

### mzr-11507 · High performance pump series

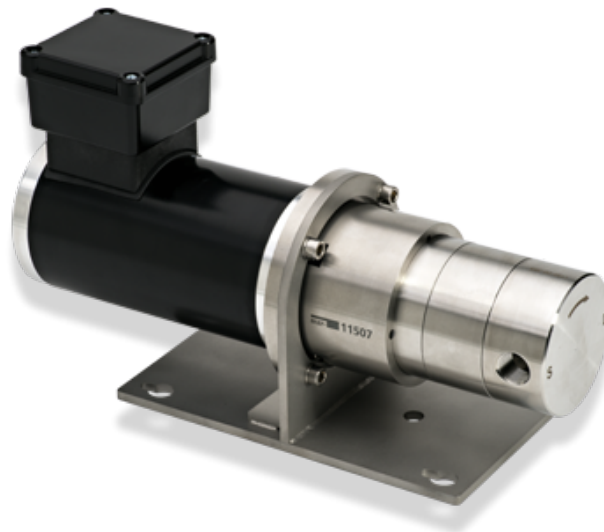

#### Description

The micro annular gear pump mzr-11507 is equipped with tungsten carbide rotors and bearings. Hard construction material and precision manufacturing techniques guarantee excellent dosage precision, high service life and wear resistance for low volume dosage of non-lubricating liquids. Driven by a high-power three-phase AC-motor the pump has a compact design and covers the flow range from 29 ml/min to 1152 ml/min. The mzr-11507 is suitable for continuous delivery and discrete dosage of low and high viscosity liquids. It achieves high differential pressures and provides a low pulsation flow. Its robustness and the available accessories make it suitable for challenging applications.

#### Advantages

- High dosage precision  
precision CV < 1% at low volumes
- Long service life  
wear-resistant tungsten carbide
- Broad viscosity range  
methanol, water, solvents, adhesives, grease, gel
- High-power motor  
AC-motor for use with external frequency inverter
- Compact dimensions  
length 303 mm
- High differential pressures  
achievable even for low viscosity liquids
- Low pulsation delivery, low shear stress  
rotary micro annular gear technology

#### Applications

- Chemical processing
- Industrial and plant engineering
- Packaging
- Medical and pharmaceutical industry
- Mini plant technology
- Spraying
- Dispensing of adhesives
- Ink and paint dosage
- Vacuum applications

## Technical data

Flow rate	29 - 1,152 ml/min
Displacement volume	192µl
Differential pressure range	0 – 140 bar (2,030 psi)
Maximum inlet pressure	10 bar (145 psi)
Ambient temperature range	-20 ... +40 (-4 ... +104 °F)°C
Liquid temperature range	-5 ... +60 °C (-20 ... +120 °C *) (+23 ... +140 °F (-4 ... +248 °F))
Viscosity range	0.3 – 150,000mPas
Precision CV	< 1% (Coefficient of variation CV)
Velocity range	150 - 6,000 rpm
Fluid connection	3/8" NPT internal thread, lateral optional 3/8" NPT internal thread, frontal
Wetted parts	stainless steel 316L (1.4435), tungsten carbide Ni-based; shaft seal: graphite-reinforced PTFE, alloy C276 (2.4819); static seals: FPM, optional: EPDM, FFPM
Motor	AC-motor, IEC-Size 056, 4 poles, IP 55, rated voltage 240/400 V, rated frequency 100 Hz, 240 W
Temperature protection	thermal contact (NC)
Dimensions (L x W x H)	303 x 110 x 171 mm
Weight	approx. 9,300 g
Remarks	* with optional heat insulation or heating module, Customized solutions on request.

### Notice

Even if single parameters are within the indicated performance range of technical data, certain parameter combinations may not be achievable. Single parameters may exceed their indicated performance range under adequate circumstances. For detailed evaluation please contact HNP Mikrosysteme. Actual performance may vary. Specifications are subject to change without notice.

## Accessories

- Heat insulation module
- Electrical heating module
- Reservoir Plastic
- Double shell heating module

## Dimensions

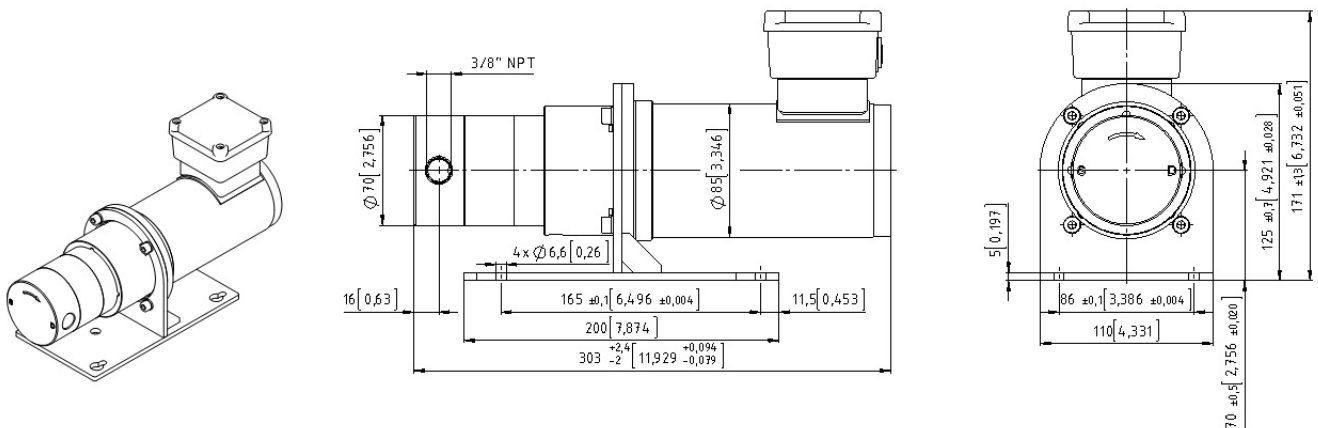

## Flow charts

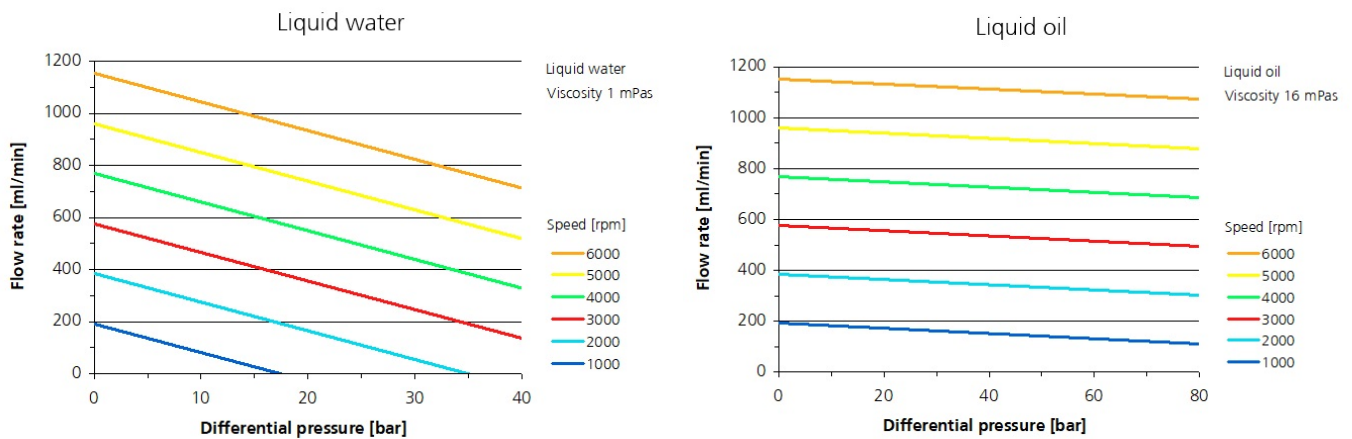

## Patents and trademarks

Micro annular gear pumps (and housings) are protected by assigned patents: EP 1 354 135 B1; US 7,698,818 B2; DE 10 2011 001 041 B4; CN 103 348 141 B; US 10,012,220 B2; CN 103 732 921 B; US 9,404,492 B2; US 6,520,757 B1.

HNPM<sup>®</sup>, mzi<sup>®</sup>, MoDoS<sup>®</sup>,  $\mu$ -Clamp<sup>®</sup>,  $\mu$ Dispense<sup>®</sup>, Centifluidic Technologies<sup>®</sup>, LiquiDoS<sup>®</sup>, smartDoS<sup>®</sup>, ColorDoS<sup>®</sup> are registered German trademarks of HNP Mikrosysteme GmbH.

## Contact

HNP Mikrosysteme GmbH  
Bleicherufer 25  
19053 Schwerin  
Germany

T +49 385 52190-300  
F +49 385 52190-333  
info@hnp-mikrosysteme.de

Last update 2019/08