

Hermetic, chemically inert pump series

Micro annular gear pump m zr[®]-11558

For microreaction technology and flow chemistry



Novelty 2011

- **High resistance to corrosion**
oxidizing and reducing media, acids and bases
- **Hermetically sealed**
magnetic coupling (NdFeB)
- **Long service life**
wear-resistant tungsten carbide
- **Chemically inert pump head**
alloy C22, SiC, Al₂O₃ and ZrO₂ ceramics
- **Dynamic precision motor**
brushless DC-motor with encoder
- **High differential pressures**
achievable even for low viscosity liquids
- **Precise dosage, low pulsation**
rotary micro annular gear technology, no valves

The m zr-11558 micro annular gear pump of the hermetic and chemically inert series is, considering its almost universal suitability for aggressive and corrosive media, a revolution in the pump

technology. Its rotors and functional elements being made of ceramics, the pump shows the highest chemical resistance and an outstanding resistance to wear. Thanks to the use of ceramics as

bearing and shaft material, a magnetic coupling, and case components made out of alloy C22 (DIN 2.4602), this pump will take up any challenge in the chemical industry applications.

Applications

- Flow chemistry
- Microreaction technology
- Mini plant technology

Technical data

Flow rate	0.19 – 1152 ml/min
Smallest dosage volume	100 µl
Displacement volume	192 µl
Differential pressure range	0 – 30 bar (1 mPas); 0 – 60 bar (> 16 mPas)
Max. system pressure	60 bar (870 psi) (inlet pressure+differential pressure)
Operating temperature range	-5 ... +60 °C (-20 ... +100 °C *)
Viscosity range	0.3 – 1,000 mPas
Precision	< 1 % Coefficient of Variation CV
Pulsation	< 6 %
Speed range	1 – 6000 rpm
Fluid connection	3/8" NPT internal thread, lateral
Wetted parts	Pump case alloy C22 (2.4602), optional: stainless steel 316L; seals FPM (Kalrez [®] Spectrum [™] 6375), optional: FPM, EPDM; shaft sintered silicon carbide (SiC); bearing and wetted functional parts Al ₂ O ₃ ceramics; rotors partially stabilized ZrO ₂ , optional: tungsten carbide Ni-based
Motor	brushless DC-motor, IP 54, 42 V DC, max. 368 W
Encoder	500 counts per turn, type HEDL 5640
Interface	motor cable length 3 m, 6-pole plug for motor winding, 12-pole plug for encoder and hall sensors
Measurements (L x B x H)	301 x 130 x 129 mm
Weight	approx. 11 kg

Customized solutions on request. * with optional heating module

Contact

HNP Mikrosysteme GmbH
Juri-Gagarin-Ring 4 · D-19370 Parchim

phone +49| 3871| 451-301
fax +49| 3871| 451-333

e-mail info@hnp-mikrosysteme.de
http://www.hnp-mikrosysteme.de

Measurements

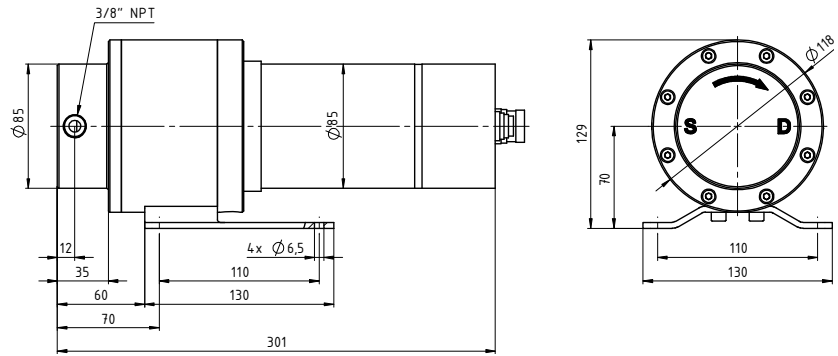
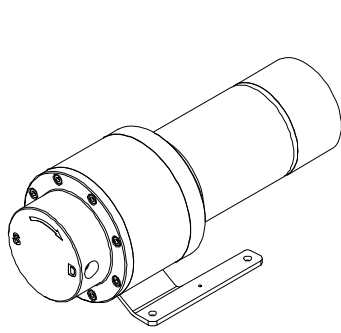

Subject to technical changes.

Flow charts

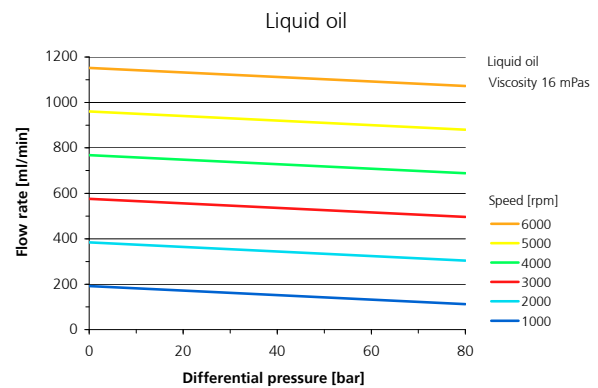
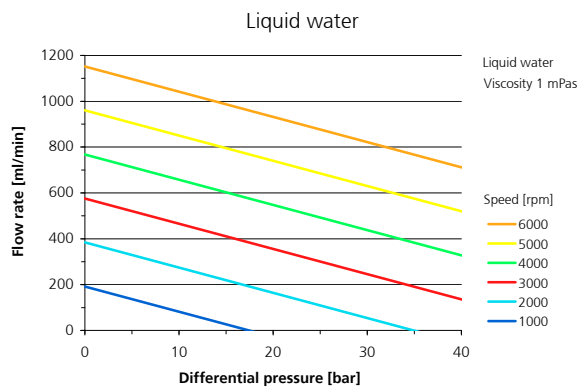

Control and software (optional)



- speed control S-HV for continuous delivery tasks
- servo-amplifier in a rugged aluminum case
- speed range 10 – 6000 rpm

- supply voltage 11 – 70 V DC, nominal current up to 10 A (optional max. current 20 A)
- internal potentiometer for speed control (optional external potentiometer)
- item no. 66 03 01 01



- speed and position control S-HP-E for continuous and discrete dispensing tasks
- 4-Q-DC servo amplifier in a rugged aluminum case
- supply voltage 20 – 55 V DC, nominal current up to 10 A

- speed range 1 – 6000 rpm
- standard interface: RS-232, CANopen
- software »Composer«
- 10 digital inputs 24 V DC
- 5 digital outputs 24 V DC
- item no. 66 04 01 24

Item number

13 01 01 01
13 01 02 01
13 01 03 01
13 01 04 01

pump mzr-11558-hs S with brushless DC-motor, lateral fluid connection 3/8" NPT
pump mzr-11558-cs S with brushless DC-motor, lateral fluid connection 3/8" NPT
pump mzr-11558-cy S with brushless DC-motor, lateral fluid connection 3/8" NPT
pump mzr-11558-hy S with brushless DC-motor, lateral fluid connection 3/8" NPT

Accessories

Liquid supply accessories
Heating module
Power supply

threaded fluid connectors, tubes, filters etc.
active heating of the pump head up to 150 °C operating temperature
power supply, assembly, 480 W, 48 V DC, 10 A, input voltage: 3 x 400 V AC
item no. 68 01 05 00

Micro annular gear pumps (and housings) are protected by assigned patents: DE 198 43 161 C2, EP 1115979 B1, US 6,520,757 B1, EP 852674 B1, US 6,179,596 B1, EP 1354135, US 7,698,818 B2. Patents pending: EP 1807546, DE 10 2009 020 942.5-24, DE 10 2011 001 041.6. In the US, Europe and Japan additional patents are pending. mZr®, MoDoS®, µ-Clamp® are registered German trademarks of HNP Mikrosysteme GmbH. Kalrez® Spectrum™ is a registered trademark of DuPont.