

## Modular Dosing System MoDoS

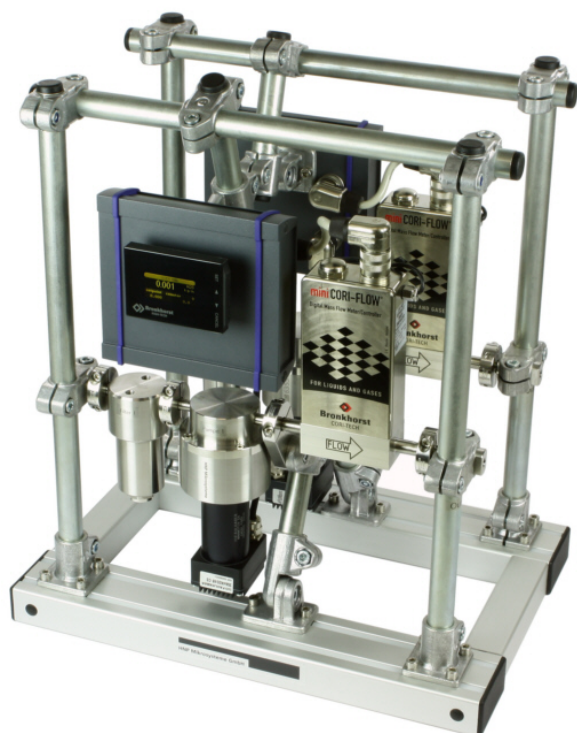

- **Ready-to-use unit**  
fully equipped and assembled system
- **Modular system of components**  
individually equipped with micro annular gear pump, filter, flow controller, fluid connections, valves, optional sensors for pressure and temperature
- **Chemical resistant materials**  
material combinations from stainless steel / hard metal to alloy C22 / ceramics, optional titanium or tantalum
- **High process stability**  
mass or volume flow controlled micro annular gear pumps
- **Standard fluidic interfaces**  
screw-in fittings or aseptic  $\mu$ -Clamp
- **Local controller**  
integrated controller allows stand-alone mode as well as integration into external process control systems
- **Open design**  
easy access and exchange of all components
- **Spatial unrestricted fixing**  
fastening system with wide assortment of Cartesian and polar interlocking elements
- **Rugged spatial structure**  
rigid framework

The customer request for ready-to-use, modular dosing systems is met by HNP Mikrosysteme with their dosing system MoDoS. It is optimized for the use in process intensification, in fine chemical and pharmaceutical production, micro process engineering and mini plants, customized to the client's special needs. This novel closed loop controlled dosing system generally integrates filter, micro annular gear pump and flow meter. The implementation of pressure sensors and temperature sensors is optional. The result is high process stability. A quickly acting closed loop control leads to constant mass

flows and in consequence to a very constant stoichiometry in reactions under conditions of continuous flow. The modular 3-dimensional construction does allow a nearly unrestricted choice of the single components and an optimal adaptation of the system to the current dosing application. The open design with all options to arrange components offers the opportunity to integrate further equipment like static or dynamic mixers. Fluidic interfaces between the components of MoDoS are optimized for minimal dead volume and easy cleaning. The novel, in-house developed  $\mu$ -Clamp is an aseptic fluid

connector for easy handling and with a dead volume reduced to a minimum at technical limits. This minimizes material loss when handling valuable and highly expensive fluids and is especially important for applications in pharmaceutical industry. Electric interfaces facilitate easy integration into external process control systems. Moreover, mass or volume flow can be adjusted by a precision potentiometer with digital display in a stand-alone mode. The rugged framework is adaptable in grid dimension and profile to fit into existing plants or to be integrated in a plant layout.

### Contact

HNP Mikrosysteme GmbH  
Juri-Gagarin-Ring 4 · D-19370 Parchim

phone +49| 3871| 451-301  
fax +49| 3871| 451-333

e-mail [info@hnp-mikrosysteme.de](mailto:info@hnp-mikrosysteme.de)  
<http://www.hnp-mikrosysteme.de>

## Applications

- Micro process technology
- Fine chemistry
- Pharmaceutical industry
- Mini plant technology

## Components

Pumps	micro annular gear pumps of hermetic inert and high performance series for volume flows of 0.003 - 1152 ml/min at differential pressures up to 80 bar *
Filters	filters in stainless steel, alloy C22, PTFE or glass *
Mass flow controllers	measurement principal Coriolis, thermic, ultra sonic *
Fluid connections	μ-Clamp, 1/4"–28 UNEF, 1/8" NPT, 3/8" NPT *
Operating temperature range	-20 ... +150 °C *
Viscosity range	0.3 – 1000 mPas *
Wetted parts	material combinations: stainless steel / hard metal, alloy C22 / ceramics, tantalum / ceramics *
Power supply	24 V DC, 240 V AC, 400 V AC *
Display	mass flow *
Controller and interfaces	mass flow control with precision potentiometer, 0–10 V, 0(4)-20 mA, RS-232, CAN-Bus *

\* depending on the components selected

## Measurements

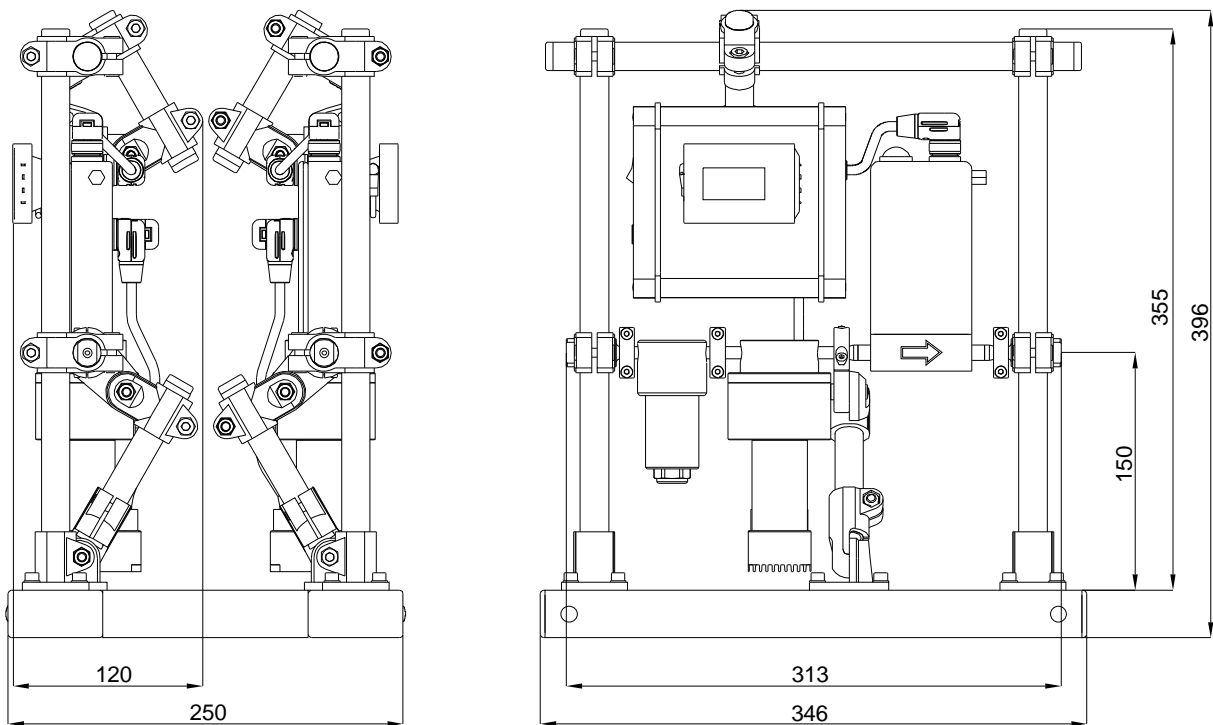

Product example, subject to technical changes.



Micro annular gear pumps (and housings) are protected by assigned patents: DE 198 43 161 C2, EP 1115979 B1, US 6,520,757 B1, EP 852674 B1, US 6,179,596 B1, EP 1354135, US 7,698,818 B2. Patents pending: EP 1807546, DE 10 2009 020 942.5-24, DE 10 2011 001 041.6. In the US, Europe and Japan additional patents are pending. mzi®, MoDoS®, μ-Clamp® are registered German trademarks of HNP Mikrosysteme GmbH.